



fenabel<sup>f</sup>  
the heart of seating

simplicity





## **MISSION**

Identify our clients needs. Design and produce custom made chairs for anywhere, in the world. Offer a unique global quality service based on the professionalism and commitment of the entire team, establishing a relationship of complete trust.

## **MISSÃO**

Identificar o que o nosso cliente pretende. Criar e produzir cadeiras personalizadas para qualquer parte do mundo.

Oferecer um serviço único de qualidade global, apoiado no profissionalismo e compromisso de toda a equipa, estabelecendo uma relação de confiança.



celebrate  
**25**  
more



Fenabel is a Portuguese family business company and wooden chairs' manufacturer which has been growing over the years.

The combination of high-tech equipment and our 96 motivated workers transformed Fenabel into a well-known leader on this sector.

Proud to reunite all the production stages ( wood preparation, assembly, finish, upholstery and packaging) we carefully supervise all the articles to make sure they reflect our quality policy.

A Fenabel é uma empresa familiar dedicada ao fabrico de cadeiras de madeira que tem vindo a crescer ao longo dos anos.

A combinação de equipamento de alta-tecnologia e os nossos 96 trabalhadores altamente motivados, transformaram a Fenabel num líder reconhecido deste setor.

Orgulhosos de reunir todas as fases da produção (preparação da madeira, montagem, acabamento, estofos e embalagem) supervisionamos todos os artigos para garantir que refletem a nossa política de qualidade.



From  
**Portugal**

To the  
**World**

# index | índice

## chairs

cadeiras

alien	100
batel	39
clip	98
cristiana	72
cristy	66
danubio	16
denim	140
denise	136
dima	146
flower	28
gin	114
golden	12
katia	112
louvre	144
messi	64
meteor	152
nyg	48
obi	82
obidos	64
ome	124
pamela	52
petra	90
sevilha	128
silá	70
simple	132
Sipe	36
voip	44

## lounge

lounge

batel	40
beket	26
chateau	148
chesterfield	138
chesterfield double	167
dakota	151
flower	34
flower double	166
gaudi	46
gaudi bx	120

jupiter	18
lua	56
madi	130
marte 01	14
mass	118
meteor	30
minister	162
nate	22
nyg	50
otto 01	142
otto double	167
paty	62
paty double	166
petra	94
petra double	166
roy	154
wing	122
wing triple	167

## bar stools

bancos bar

alien	100
batel	39
clip	98   99
cristiana	74   126
danubio	16
gin	117
golden	13
obidos	65
ome	60
petra	91
simple	132
sipe	37
voip	45

## banqueting & conference

catering & conferência

art 137	158
camaleao go	160

## ottomans

puffs

ballet	96
mika rodape	38
nyg puff	48
sagres	17
sagres mad	38

## booths

banquetas

bilbao	171
chelsea	170
chelsea high	170
dublin	170
frança 01	171
frança	171
yuma edge	170
yuma paris	171
yuma solid	170

## dining tables

mesas de jantar

bern	177
cookie lisa	177
donasella quad	175
donasella rect	175
dona quad	176
dona rect	176
gomo dining	175
jar	176
norma	177
norma tri	177
porto eco quad	179
porto eco rect	179
porto quad	179
smile 01 red	174
smile 01 quad	174
smile 01 rect	174
tess quad <small>(pe k)</small>	178
tess rect <small>(pe k)</small>	178
tess red <small>(pe k)</small>	178

## metal tables

mesas de metal

pfill 109	181
pfill 110	180
pfill 111	182
pfill 400 q	182
pfill 400 bq	183
pfill 405	180
pfill 405 s	183
pfill 430	181
pfill 430 bar	181
pfill 431	182
pfill 4490	180

## trolley

carrinho

wheel	184
-------	-----

## coffee - side tables

mesas de apoio

bergamo bx	190
blade h32	187
blade h38	187
blade h45	187
carter sp 100	185
carter 200	185
carter 300	185
copper	186
dante	186
dum	186
geo	189
geo wire	189
gillo 2	188
gillo 3	188
gomo side oval	184
gomo side red	184
kactus	189
marbel	188
smile 01 low	185
twist	190



alien  
100 | 111



batel  
38 | 43



cristiana  
72 | 81



cristy  
66 | 69



danubio  
16 | 21



denim  
140 | 141



denise  
136 | 137



dima  
146 | 147



flower  
28 | 32



gin  
114 | 116



golden  
12 | 24



katia  
144 | 1



louvre  
142 | 150



messi  
84 | 85



meteor  
152



nyg  
48



obi  
82 | 87



ome  
124 | 127



pamela  
52 | 57



petra  
90 | 96



chairs | cadeiras

sevilha  
128



sila  
70 | 71



simple  
132 | 135



sipe  
36 | 37



voip  
44 | 45



lounge | lounge

batel  
40 | 41



beket  
26 | 27



chateau  
148 | 149



chesterfield  
138 | 167



dakota  
151



flower  
34 | 166



gaudi  
46 | 47



gaudi bx  
120 | 121



index | índice

jupiter  
18 | 19



lua  
58 | 59



madi  
130 | 131



marte 01  
14 | 15



mass  
118 | 119



meteor  
156 | 157



minister  
162 | 163



nate  
22 | 23



nyg  
50 | 51



otto  
142 | 167



paty  
62 | 166



petra  
94 | 166



wing  
122 | 167



**bar stools** | *bancos bar*

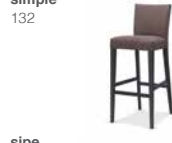

# index | índice

**ottomans** | *Puffs*

ballet  
96



mika rodape  
38



nyg puff  
48



sagres  
17



sagres mad  
38



**booths** | *banquetas*

bilbao  
171



chelsea  
170



chelsea high  
170



dublin  
170



frança 01  
171



frança  
171



yuma edge  
170



yuma paris  
171



yuma solid  
170



**banqueting & conference** | *catering & conferência*

art 137  
158 | 159



camaleao go  
160 | 161



## dining table | mesa de jantar



## metal table | mesa de metal



## trolley | carrinho



## coffee - side table | mesa de apoio

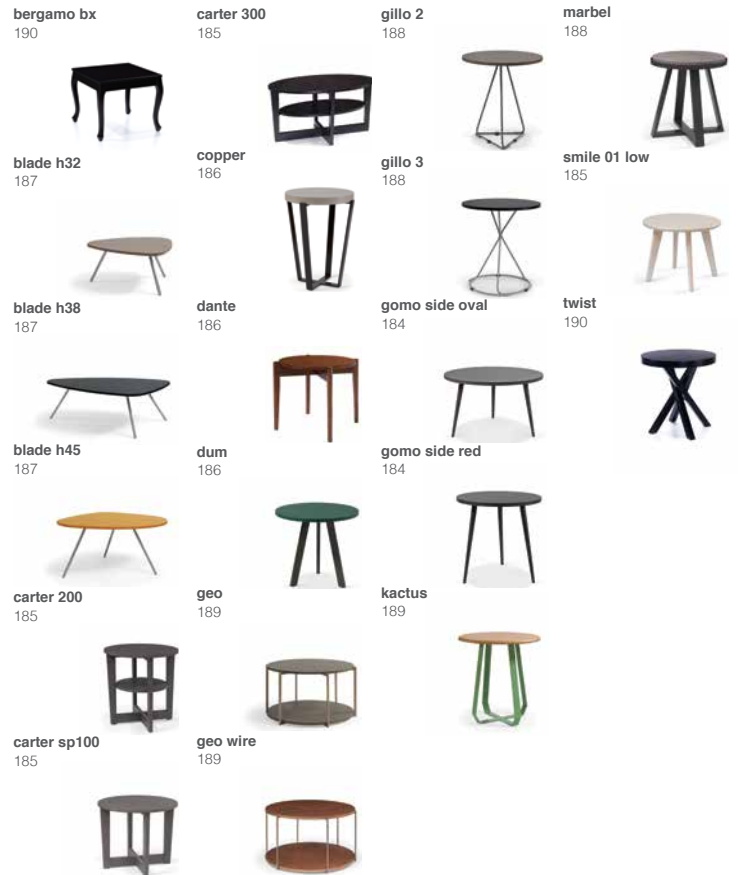

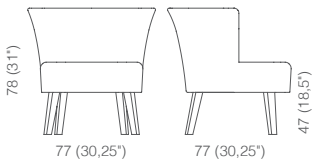

**marte 01**  
1 x box 0,55 m³ | 10,5 kg - 23,1 lb

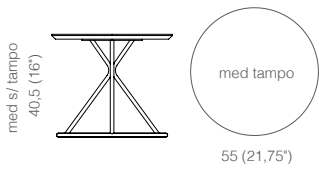

**gillo 3 h40,5**  
1 x box 0,16 m³ | 8,4 kg - 18,5 lb

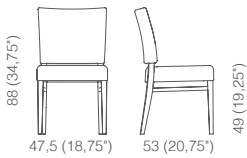

**golden hole**  
2 x box 0,31 m³ | 7 kg - 15,4 lb

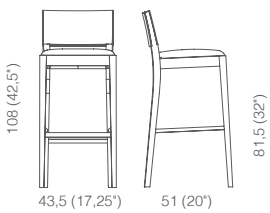

**golden pl 01 bar**  
1 x box 0,29 m³ | 7,5 kg - 16,5 lb



marte 01

gillo 3 h40,5



golden hole



golden pl 01 bar



golden hole



marte 01

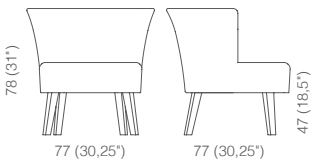

**marte 01**  
1 x box 0,55 m<sup>3</sup> | 10,5 kg - 23,1 lb



marte 01



Danubio is a stylish, contemporary and simple collection, available in a wide variety of wood finishes and fabrics. With its remarkable presence it is the perfect choice for hotels, restaurants and elegant coffee shops.

*A Danubio é uma coleção elegante, contemporânea e simples, disponível numa grande variedade de acabamentos de madeira e tecidos. Com a sua presença marcante, é a escolha perfeita para hotéis, restaurantes e cafés que primam pela elegância.*



danubio rec bar

danubio bx emp

danubio maple 01

danubio hole

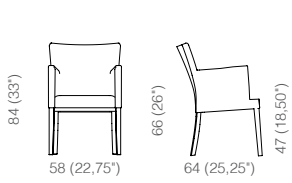

**danubio maple 01**  
1 x box 0,34 m<sup>3</sup> | 8 kg - 17,6 lb

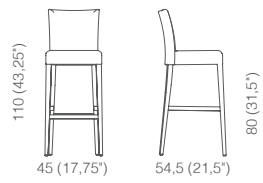

**danubio rec bar**  
1 x box 0,31 m<sup>3</sup> | 7,5 kg - 16,5 lb

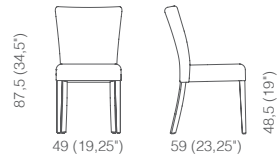

**danubio bx emp**  
2 x box 0,40 m<sup>3</sup> | 8 kg - 17,6 lb

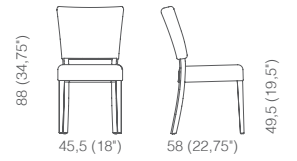

**danubio hole**  
2 x box 0,36 m<sup>3</sup> | 6,5 kg - 14,3 lb

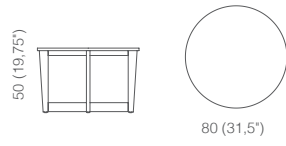

**carter sp100**  
1 x box 0,24 m<sup>3</sup> | 19 kg - 41,9 lb

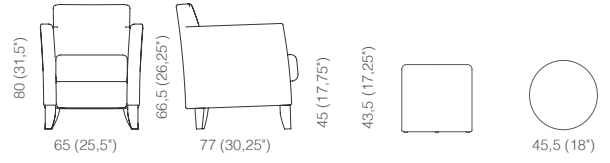

**jupiter**  
1 x box 0,46 m<sup>3</sup> | 14,5 kg - 32 lb

**sagres**  
2 x box 0,29 m<sup>3</sup> | 5 kg - 11 lb



carter sp 100

jupiter

sagres



jupiter

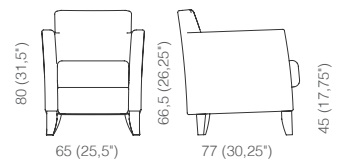

**jupiter**  
1 x box 0,46 m<sup>3</sup> | 14,5 kg - 32 lb



jupiter

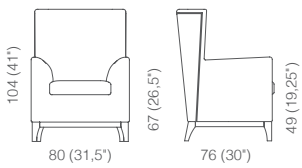

**nate**  
1 x box 0,81 m³ | 21 kg - 46,3 lb

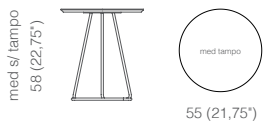

**gillo 2**  
1 x box 0,18 m³ | 6,3 kg - 13,9 lb

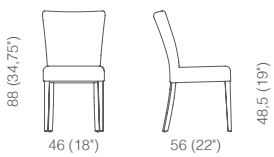

**danubio bx**  
2 x box 0,35 m³ | 5,5 kg - 12,1 lb

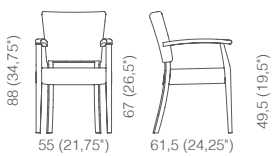

**danubio bx hole cb bk**  
1 x box 0,34 m³ | 8 kg - 17,6 lb

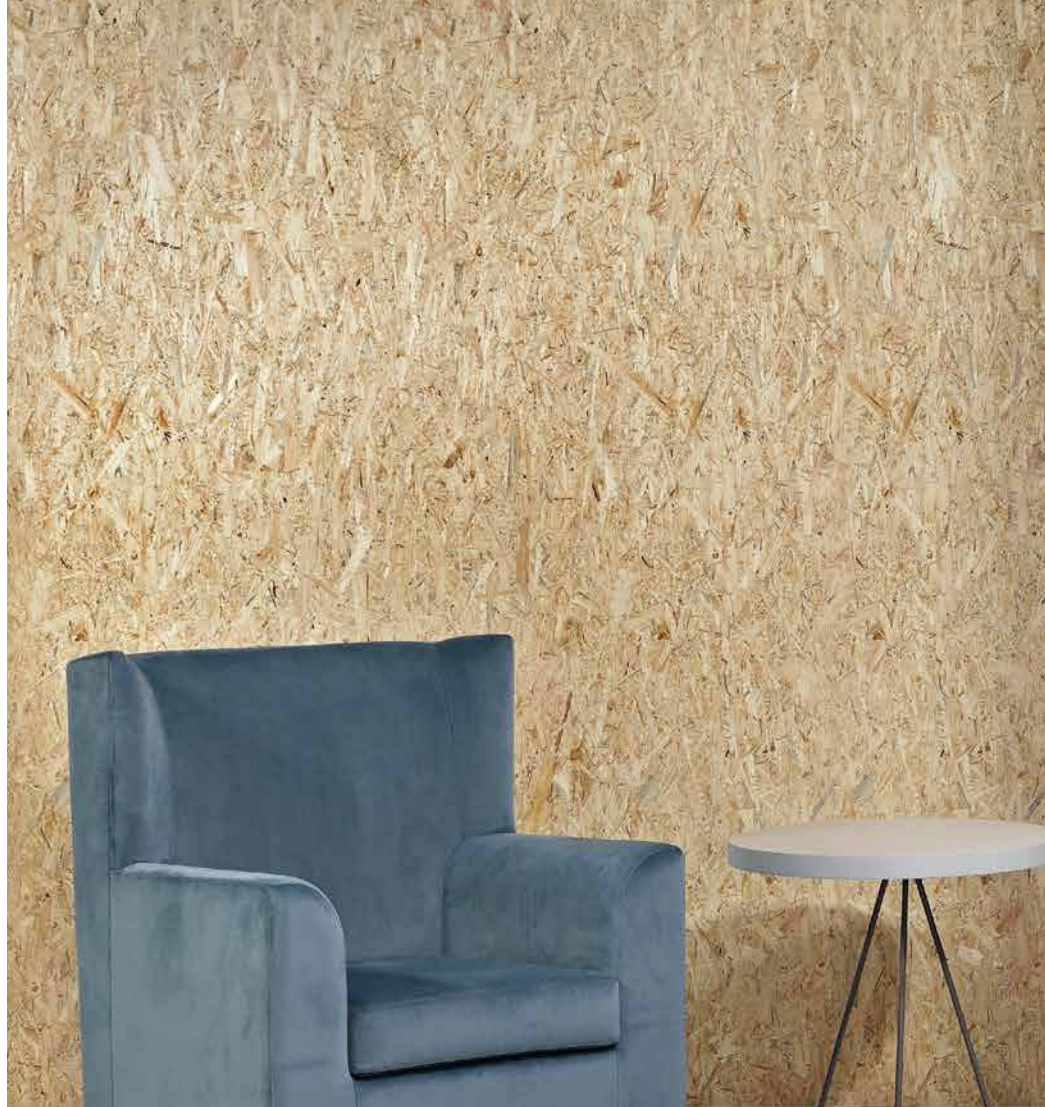

nate



gillo 2





danubio bx



danubio bx hole cb bk



danubio bx hole cb bk



nate



nate

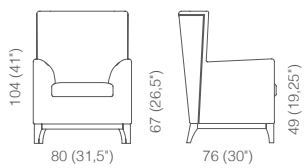

**nate**  
1 x box 0,81 m<sup>3</sup> | 21 kg - 46,3 lb





golden est pl tp



golden pl tp



golden est pl tp

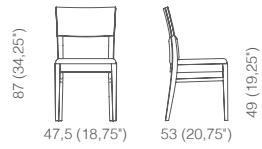

**golden est pl tp**  
2 x box 0,31 m<sup>3</sup> | 7 kg - 15,4 lb

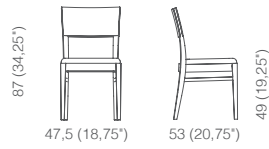

**golden pl tp**  
2 x box 0,31 m<sup>3</sup> | 6,5 kg - 14,3 lb

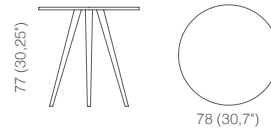

**gomo dining red**  
1 x box 0,56 m<sup>3</sup> | 11 kg - 24,3 lb

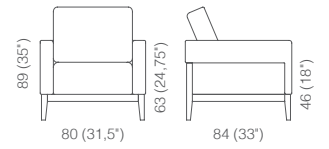

**beket mad**  
1 x box 0,55 m<sup>3</sup> | 29,5 kg - 65 lb



gomo dining red



beket mad



beket mad

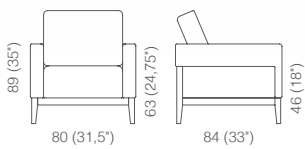

**beket mad**  
1 x box 0,55 m<sup>3</sup> | 29,5 kg - 65 lb



beket mad

It is a collection with a strong character and a design focused on comfort. Offers a wide range of elegant solutions such as: chair, armchair and lounge chair.

É uma coleção com um caráter forte e um design focado no conforto. Oferece uma ampla gama de soluções elegantes, tais como: cadeira, poltrona e lounge.



flower 01

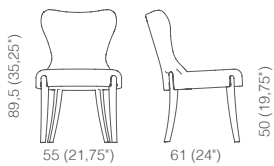

**flower 01**  
2 x box 0,40 m<sup>3</sup> | 7,5 kg - 16,5 lb

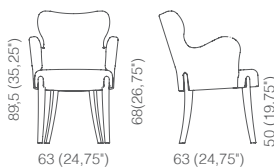

**flower 01 cb**  
1 x box 0,34 m<sup>3</sup> | 9,5 kg - 20,9 lb



flower 01 cb

flower 01



flower 01 cb

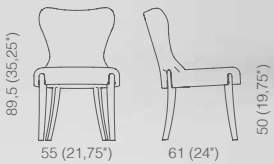

flower 01

**flower 01**  
2 x box 0,40 m<sup>3</sup> | 7,5 kg - 16,5 lb

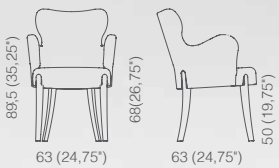

**flower 01 cb**  
1 x box 0,34 m<sup>3</sup> | 9,5 kg - 20,9 lb



flower 01

flower 01 cb



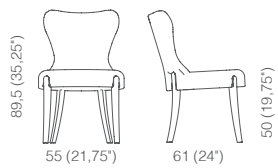

**flower 01**  
2 x box 0,40 m<sup>3</sup> | 7,5 kg - 16,5 lb

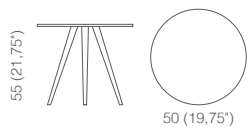

**gomo side red h55**  
1 x box 0,18 m<sup>3</sup> | 5,3 kg - 11,7 lb

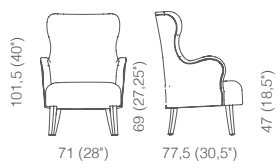

**flower lounge**  
1 x box 0,60 m<sup>3</sup> | 13,5 kg - 29,8 lb



flower 01



gomo side red h55

flower lounge



flower lounge

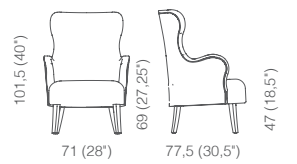

**flower lounge**  
1 x box 0,60 m<sup>3</sup> | 13,5 kg - 29,8 lb



flower lounge



sipe cb



sipe cb

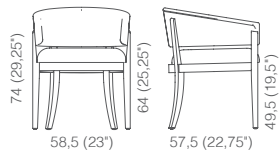

**sipe cb**  
1 x box 0,30 m³ | 10,5 kg - 23,1 lb

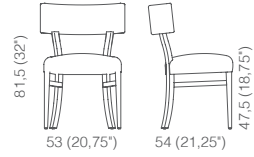

**sipe**  
2 x box 0,42 m³ | 7 kg - 15,4 lb

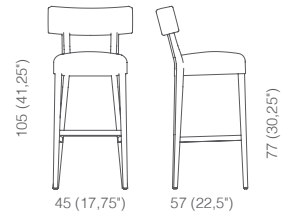

**sipe bar**  
1 x box 0,29 m³ | 7 kg - 15,4 lb



sipe bar

sipe

sipe

Available with back and seat in beech solid wood or with upholstered seat, Batel collection has a complex construction but with a clean light design.

*Disponível com costas e assento em madeira maciça de faia ou com o assento estofado, a coleção Batel tem uma construção complexa, mas um design simples e leve.*



mika rodape



geo wire h51



sagres mad

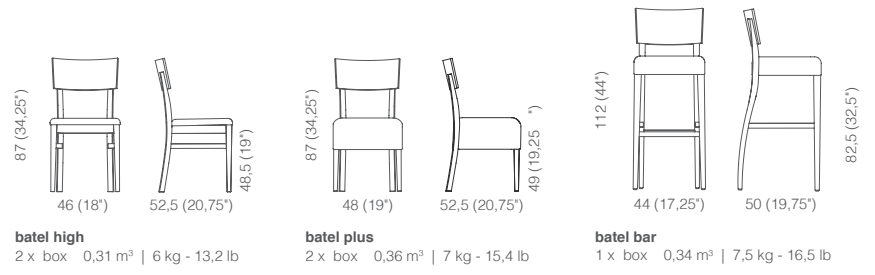
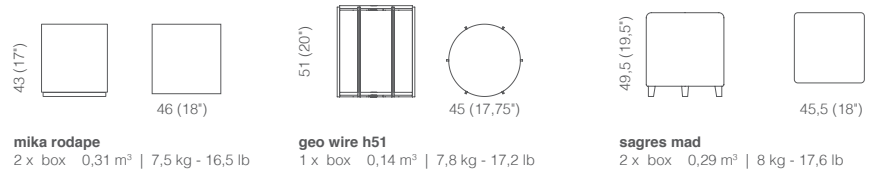

batel high

batel plus

batel bar





batel mass

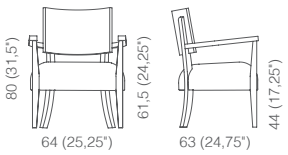

**batel mass**  
1 x box 0,34 m<sup>3</sup> | 10 kg - 22,1 lb



batel mass

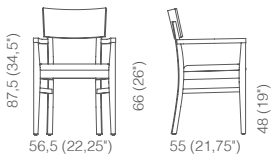

**batel cb**  
1 x box 0,34 m³ | 8 kg - 17,6 lb

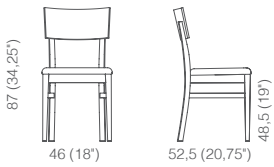

**batel high**  
2 x box 0,31 m³ | 6 kg - 13,2 lb

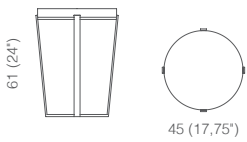

**copper h61**  
1 x box 0,17 m³ | 8,1 kg - 17,9 lb

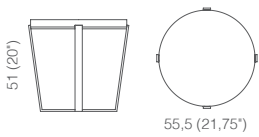

**copper h51**  
1 x box 0,20 m³ | 10,5 kg - 23,1 lb

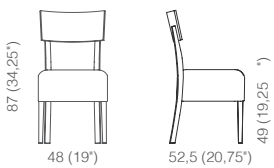

**batel plus**  
2 x box 0,36 m³ | 7 kg - 15,4 lb



batel cb



batel high



copper h 61



copper h 51



batel plus



voip



gillo 2



voip cb

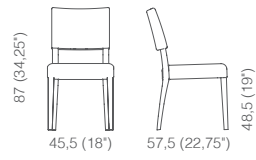

**voip**  
2 x box 0,31 m<sup>3</sup> | 6,5 kg - 14,3 lb

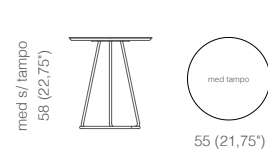

**gillo 2 h58**  
1 x box 0,23 m<sup>3</sup> | 6,3 kg - 13,9 lb

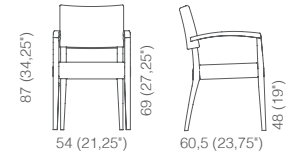

**voip cb**  
1 x box 0,34 m<sup>3</sup> | 8 kg - 17,6 lb

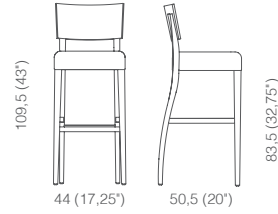

**voip bar**  
1 x box 0,31 m<sup>3</sup> | 7,5 kg - 16,5 lb

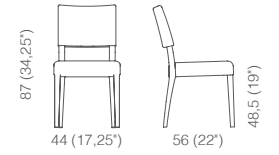

**voip emp tp**  
2 x box 0,31 m<sup>3</sup> | 7,5 kg - 16,5 lb



voip bar



voip emp tp

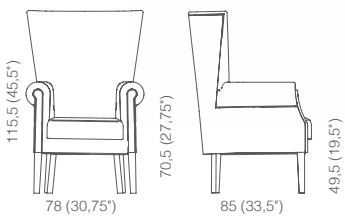

**gaudi**  
1 x box 0,75 m<sup>3</sup> | 17,5 kg - 38,6 lb



gaudi





nyg small



nyg cb



nyg puff

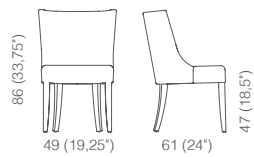

**nyg small**  
1 x box 0,34 m<sup>3</sup> | 9,5 kg - 20,9 lb

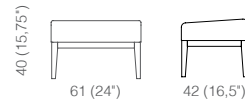

**nyg puff**  
2 x box 0,31 m<sup>3</sup> | 6,5 kg - 14,3 lb

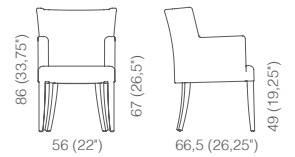

**nyg cb**  
1 x box 0,33 m<sup>3</sup> | 11,5 kg - 25,4 lb

Extremely comfortable and distinct Nyg collection, is composed of a chair, an armchair, a lounge chair and a ottoman, creates in any environment the feeling of coziness and relaxation.

*A coleção Nyg extremamente confortável e distinta, é composta por cadeira, cadeirão, lounge e puf, cria em qualquer ambiente a sensação de aconchego e relaxamento.*



nyg cb



nyg mass

med s/ tampo  
59 (23,25")



55 (21,75")

**dum metal h59**

1 x box 0,23 m<sup>3</sup> | 7,5 kg - 16,5 lb

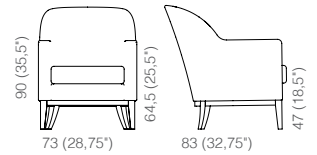

90 (35,5")

73 (28,75")

64,5 (25,5")

83 (32,75")

47 (18,5")

**nyg mass**

1 x box 0,55 m<sup>3</sup> | 17,5 kg - 38,6 lb



dum metal h59



nyg mass

Solid, simple and extremely comfortable, Pamela's collection design was updated to a more modern approach, able to fit in any interior design project.

*Sólido, simples e extremamente confortável, o design da coleção Pamela foi atualizado para uma abordagem mais moderna, capaz de se adequar a qualquer projeto de design de interiores.*



pamela 4 tab



pamela 4 tab

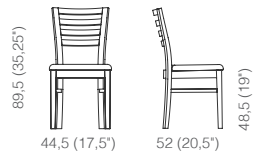

**pamela 4 tab**  
2 x box 0,31 m<sup>3</sup> | 6 kg - 13,2 lb



pamela 4 tab



pamela 4 tab

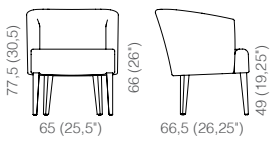

**lua**  
1 x box 0,33 m³ | 11 kg - 24,3 lb

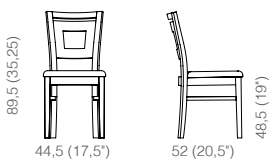

**pamela hole**  
1 x box 0,31 m³ | 6 kg - 13,2 lb

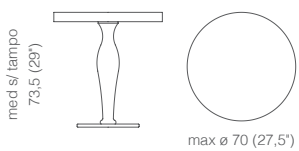

**jar**  
1 x box 0,14 m³ | 28 kg - 61,75 lb



lua



pamela hole



jar



pamela hole



Manufactured in solid beech wood the Palmela range is a dynamic collection with the right construction to withstand the requirements of a contract environment.

*Fabricado em madeira de faia sólida, a gama Palmela é uma coleção dinâmica com uma construção resistente, desenhada para suportar os requisitos de um ambiente de contract.*



pamela ee



pamela ee

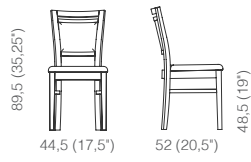

**pamela ee**  
2 x box 0,31 m<sup>3</sup> | 6 kg - 13,2 lb

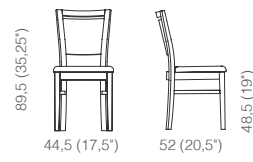

**pamela**  
2 x box 0,31 m<sup>3</sup> | 6 kg - 13,2 lb

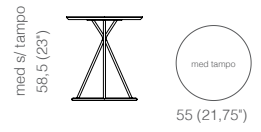

**gillo 3 h 58,5**  
1 x box 0,23 m<sup>3</sup> | 9,2 kg - 20,3 lb



pamela



gillo 3 h58,5



pamela



lua



lua

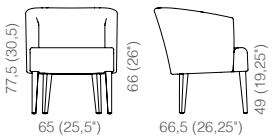

**lua**  
1 x box 0,33 m<sup>3</sup> | 11 kg - 24,3 lb

The Cristiana collection offers a classic yet stylish solution. It is extremely versatile able to fit in all kinds of spaces, meeting rooms, reception areas, coffee shops and restaurants.

*A coleção Cristiana oferece uma solução clássica e elegante. É extremamente versátil capaz de se incluir em qualquer tipo de espaço, desde salas de reuniões, áreas de recepção, a cafés e restaurantes.*



ome dan bar



cristiana dan



cristiana dan

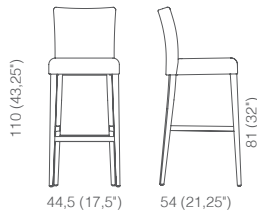

**ome dan bar**  
1 x box 0,31 m³ | 7,5 kg - 16,5 lb

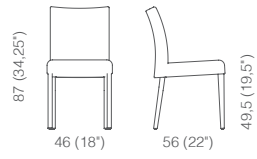

**cristiana dan**  
2 x box 0,36 m³ | 6,5 kg - 14,3 lb

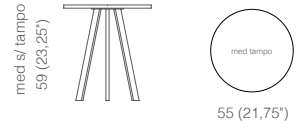

**dum metal h59**  
1 x box 0,23 m³ | 7,5 kg - 16,5 lb

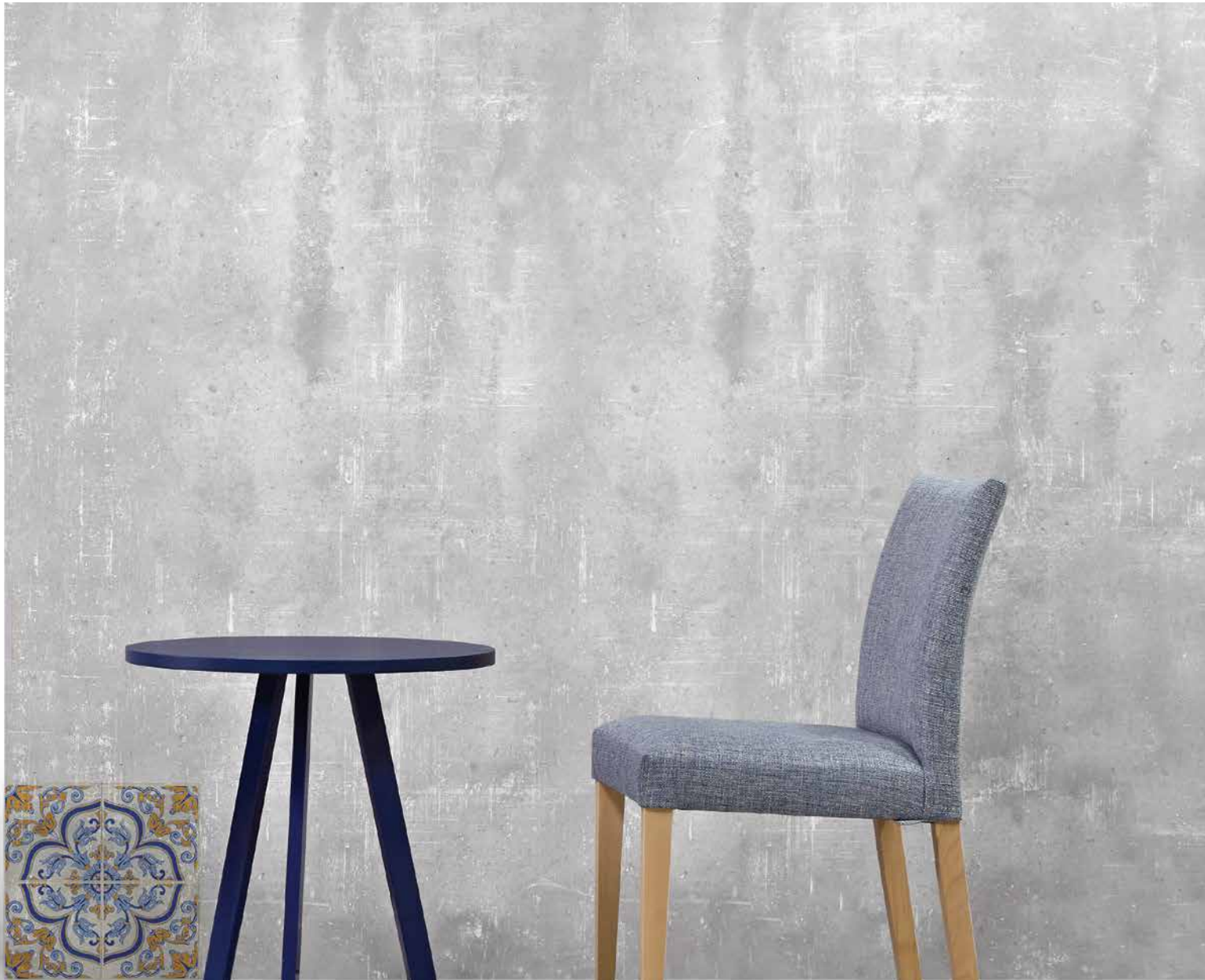

dum metal

cristiana dan



paty mass

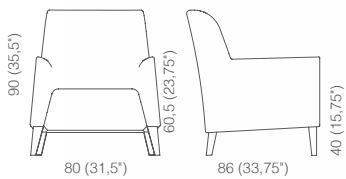

**paty mass**  
1 x box 0,65 m<sup>3</sup> | 23 kg - 50,7 lb



paty mass



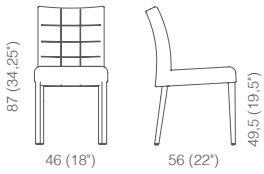

**messi Q12**  
2 x box 0,36 m<sup>3</sup> | 5,5 kg - 12,1 lb

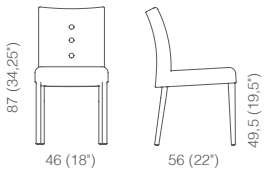

**messi B3**  
2 x box 0,36 m<sup>3</sup> | 5,5 kg - 12,1 lb

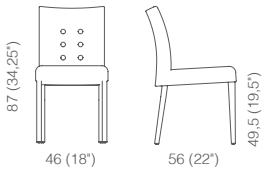

**messi B6**  
2 x box 0,36 m<sup>3</sup> | 5,5 kg - 12,1 lb

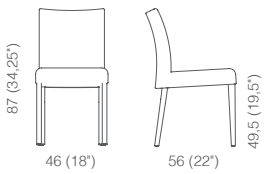

**messi**  
2 x box 0,36 m<sup>3</sup> | 5,5 kg - 12,1 lb

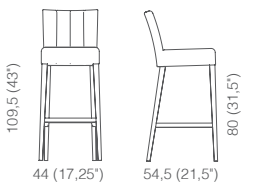

**obidos bar**  
1 x box 0,26 m<sup>3</sup> | 6 kg - 13,2 lb



messi Q12

messi B3



obidos bar



messi



messi B6

Cristy collection offers a classic style, extremely versatile and ideal to be included in any kind of space, such as coffee shops and restaurants, or even home environments.

*A coleção Cristy oferece um estilo clássico, extremamente versátil e ideal para ser incluída em qualquer tipo de espaço, como cafés e restaurantes, ou mesmo ambientes domésticos.*



cristy ee



cristy 3 tab

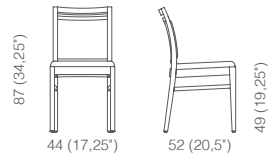

**cristy ee**  
2 x box 0,31 m<sup>3</sup> | 7 kg - 15,4 lb

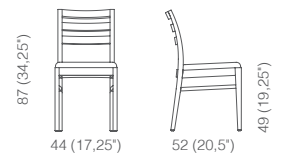

**cristy 3 tab**  
2 x box 0,31 m<sup>3</sup> | 7 kg - 15,4 lb



cristy ee



cristy 3 tab



cristy 3 tab



cristy voip 02



cristy voip 02

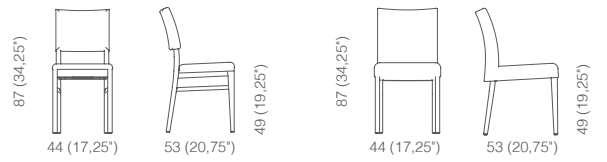

**cristy voip 02**  
2 x box 0,31 m<sup>3</sup> | 6 kg - 13,2 lb

**cristy dan**  
2 x box 0,31 m<sup>3</sup> | 6 kg - 13,2 lb



cristy dan



cristy dan

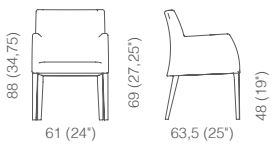

**sila maple**  
1 x box 0,34 m³ | 11,5 kg - 25,4 lb

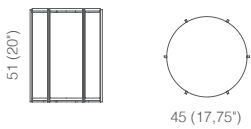

**geo wire h51**  
1 x box 0,74 m³ | 7,8 kg - 17,2 lb

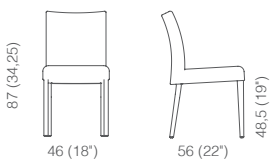

**sila**  
2 x box 0,36 m³ | 5 kg - 11 lb



sila



geo wire h51



sila maple



The Cristiana collection offers a classic yet stylish solution. It is extremely versatile able to fit in all kinds of spaces, meeting rooms, reception areas, coffee shops and restaurants.

*A coleção Cristiana oferece uma solução clássica e elegante. É extremamente versátil capaz de se incluir em qualquer tipo de espaço, desde salas de reuniões, áreas de recepção, a cafés e restaurantes.*



cristiana ee

cristiana ee

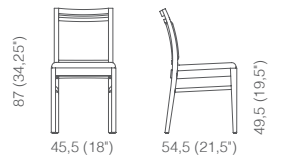

**cristiana ee**  
2 x box 0,31 m<sup>3</sup> | 6,5 kg - 14,3 lb



cristiana ee

cristiana ee



cristiana est pro



cristiana 4 tab bar

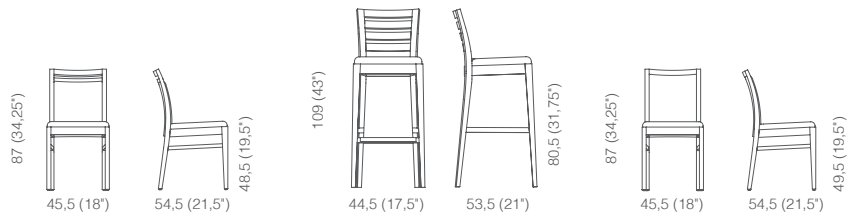

**cristiana est pro**  
2 x box 0,31 m<sup>3</sup> | 6 kg - 13,2 lb

**cristiana 4 tab bar**  
1 x box 0,31 m<sup>3</sup> | 7 kg - 15,4 lb

**cristiana est**  
2 x box 0,31 m<sup>3</sup> | 6 kg - 13,2 lb



cristiana est

cristiana est



cristiana est



cristiana est

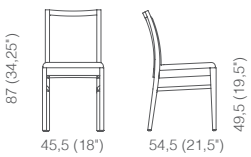

**cristiana est**  
2 x box 0,31 m<sup>3</sup> | 6 kg - 13,2 lb



cristiana est



cristiana 4 tab

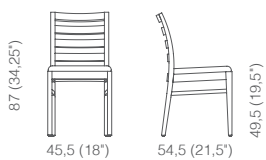

**cristiana 4 tab**  
2 x box 0,31 m<sup>3</sup> | 6,5 kg - 14,3 lb



cristiana 4 tab



cristiana 4 tab



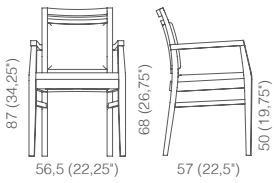

**cristiana ee cb**  
1 x box 0,34 m<sup>3</sup> | 8,5 kg - 18,7 lb

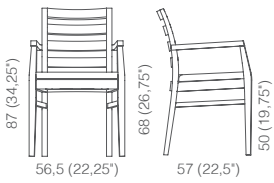

**cristiana 4 tab cb bacri**  
1 x box 0,34 m<sup>3</sup> | 8,5 kg - 18,7 lb

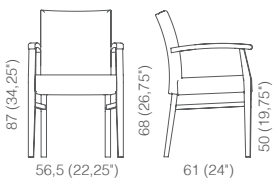

**cristiana dan cb bk**  
1 x box 0,34 m<sup>3</sup> | 8 kg - 17,6 lb



cristiana ee cb



cristiana 4 tab cb bacri



cristiana dan cb bk

Completely upholstered with simple and elegant lines, this collection is formed by a chair and an armchair which can be customized to fit perfectly in any project. This versatility is accomplished through the variety of colour finishes and fabrics available. It's one of the perfect choices for any restaurant or home interior as its elegant shape creates an exclusive comfort feeling.

*Totalmente estofada com linhas simples e elegantes, esta coleção é composta por uma cadeira de jantar e uma poltrona que poderá ser personalizada para integrar perfeitamente em qualquer projeto. Esta versatilidade é conseguida através da variedade de acabamentos de cor e tecidos disponíveis. É uma das escolhas perfeitas para qualquer restaurante ou interior de casa pois a sua forma elegante cria uma sensação de conforto exclusiva.*



obi maple

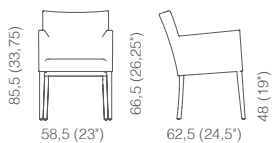

**obi maple**  
1 x box 0,34 m<sup>3</sup> | 8,5 kg - 18,7 lb



obi maple



obi maple

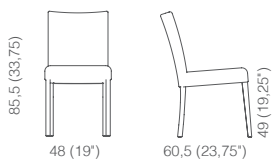

**obi**  
2 x box 0,36 m³ | 7 kg - 15,4 lb





obi



obi

Completely upholstered with simple and elegant lines, this collection is formed by a chair and an armchair which can be customized to fit perfectly in any project. This versatility is accomplished through the variety of colour finishes and fabrics available. It's one of the perfect choices for any restaurant or home interior as its elegant shape creates an exclusive comfort feeling.

*Totalmente estofada com linhas simples e elegantes, esta coleção é composta por uma cadeira de jantar e uma poltrona que poderá ser personalizada para integrar perfeitamente em qualquer projeto. Esta versatilidade é conseguida através da variedade de acabamentos de cor e tecidos disponíveis. É uma das escolhas perfeitas para qualquer restaurante ou interior de casa pois a sua forma elegante cria uma sensação de conforto exclusiva.*



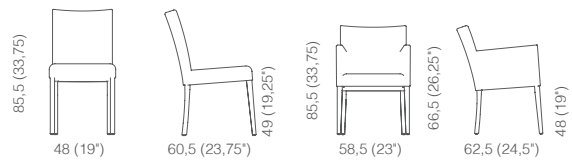

**obi**  
2 x box 0,36 m³ | 7 kg - 15,4 lb

**obi maple**  
1 x box 0,34 m³ | 8,5 kg - 18,7 lb



obi maple





obi cb

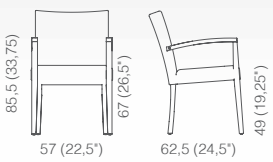

**obi cb**  
1 x box 0,34 m<sup>3</sup> | 8,5 kg - 18,7 lb



obi cb



obi cb

Petra is a stylish, contemporary and simple collection, available in a wide variety of wood finishes and fabrics. With its remarkable presence it is the perfect choice for hotels, restaurants and elegant coffee shops.

*A Petra é uma coleção elegante, contemporânea e simples, disponível numa grande variedade de acabamentos de madeira e tecidos. Com a sua presença marcante, é a escolha perfeita para hotéis, restaurantes e cafés que primam pela elegância.*



petra maple



petra cb



petra

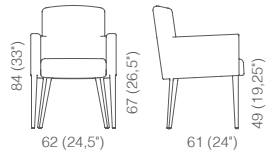

**petra maple**  
1 x box 0,33 m<sup>3</sup> | 7,5 kg - 16,5 lb

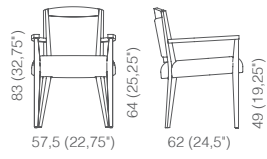

**petra cb**  
1 x box 0,34 m<sup>3</sup> | 6,5 kg - 14,3 lb

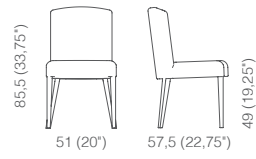

**petra**  
2 x box 0,35 m<sup>3</sup> | 6,5 kg - 14,3 lb

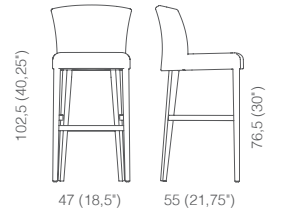

**petra bar 03**  
1 x box 0,30 m<sup>3</sup> | 6,5 kg - 14,3 lb



petra



petra bar 03



petra dan cb

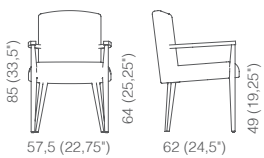

**petra dan cb**

1 x box 0,34 m<sup>3</sup> | 6,5 kg -14,3 lb



petra dan cb



petra mass

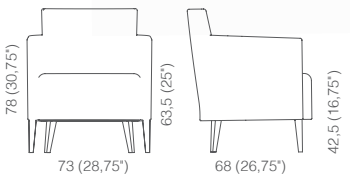

**petra mass**  
1 x box 0,46 m<sup>3</sup> | 15,5 kg - 34,2 lb



petra mass





petra maple mad



ballet

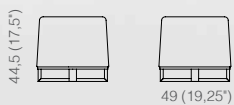

**ballet**  
2 x box 0,31 m³ | 8,5 kg -18,7 lb

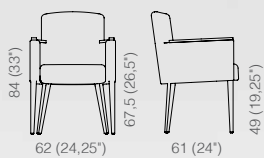

**petra maple mad**  
1 x box 0,34 m³ | 7,5 kg -16,5 lb



blade h38

petra double



**blade h38**  
1 x box 0,37 m³ | 10,2 kg - 22,5 lb

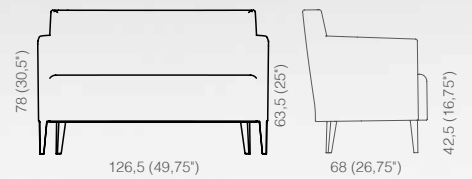

**petra double**  
1 x box 1,27 m³ | 22 kg - 48,5 lb

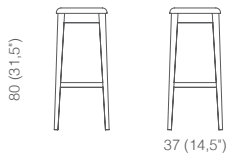

**clip 2 bar**  
2 x box 0,11 m<sup>3</sup> | 5 kg - 11 lb

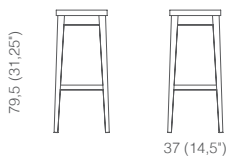

**clip 1 bar**  
2 x box 0,23 m<sup>3</sup> | 6,5 kg - 14,3 lb

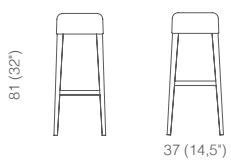

**clip 3 bar**  
2 x box 0,11 m<sup>3</sup> | 5 kg - 11 lb



clip 2 bar



clip 1 bar



clip 3 bar

The wide variety of options together with its smoothness of the curved back enhances the comfort offered by the Alien collection making this an ideal option to any contract environment that is focused on the comfort and well being of its clients.

*A ampla variedade de opções, juntamente com suavidade do design das costas curvas, aumentam o conforto oferecido pela coleção Alien, tornando esta uma opção ideal para qualquer ambiente de contract focado no conforto e no bem-estar dos seus clientes.*



alien dan bar



alien ee

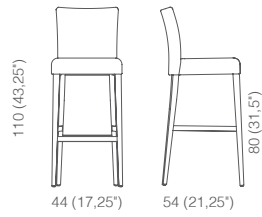

**alien dan bar**  
1 x box 0,31 m<sup>3</sup> | 7,5 kg - 16,5 lb

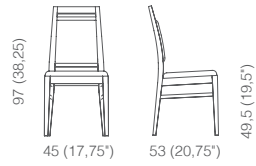

**alien ee**  
2 x box 0,31 m<sup>3</sup> | 6,5 kg - 14,3 lb

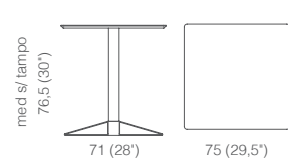

**norma h76,5**  
1 x box 0,14 m<sup>3</sup> | 15 kg - 33,1 lb

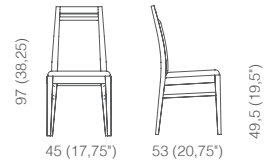

**alien est pro**  
2 x box 0,31 m<sup>3</sup> | 7 kg - 15,4 lb



norma

alien est pro



alien pl

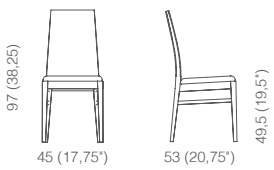

**alien pl**  
2 x box 0,31 m³ | 7 kg - 15,4 lb



alien pl



alien pl





alien ee cb bk



alien ee cb bk



alien ee cb bk

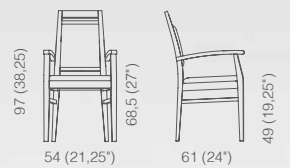

**alien ee cb bk**  
1 x box 0,37 m<sup>3</sup> | 9 kg - 19,8 lb



alien 4 tab



alien 4 tab

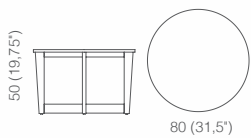

**carter sp100**  
1 x box 0,24 m³ | 19 kg - 41,9 lb

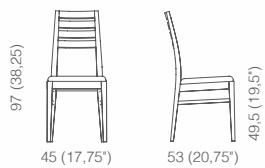

**alien 4 tab**  
2 x box 0,31 m³ | 6,5 kg - 14,3 lb



alien 4 tab



carter sp 100



alien 4 tab cb bk

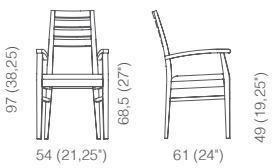

**alien 4 tab cb bk**  
1 x box 0,37 m<sup>3</sup> | 9 kg - 19,8 lb

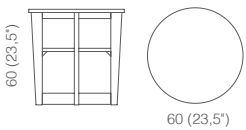

**carter 200**  
1 x box 0,24 m<sup>3</sup> | 10,5 kg - 23,1 lb



alien 4 tab cb bk



carter 200



alien dan



alien dan

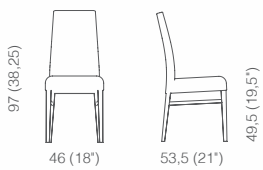

**alien dan**  
2 x box 0,31 m<sup>3</sup> | 6,5 kg - 14,3 lb

alien dan





katia est cb bk



katia est

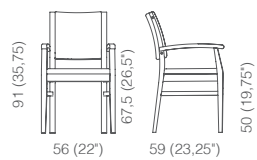

**katia est cb bk**  
1 x box 0,34 m³ | 9 kg - 19,8 lb

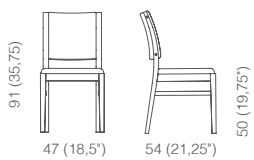

**katia est**  
2 x box 0,36 m³ | 7 kg - 15,4 lb

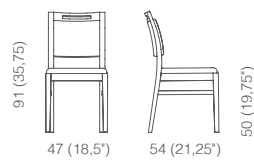

**katia zu**  
2 x box 0,36 m³ | 6,5 kg - 14,3 lb

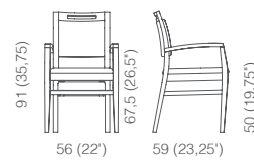

**katia zu cb**  
1 x box 0,37 m³ | 8 kg - 17,6 lb



katia zu



katia zu cb



gin est 02

gin pl 01

gin pl 01



gin pl 01

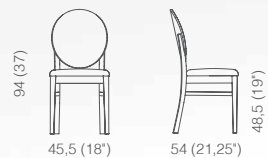

**gin pl 01**  
2 x box 0,31 m³ | 6,5 kg - 14,3 lb

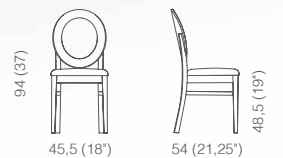

**gin est 02**  
2 x box 0,31 m³ | 6,5 kg - 14,3 lb



cookie lisa



gin



gin cb bk

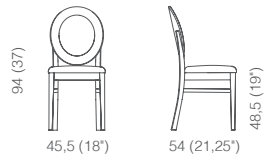

**gin**  
2 x box 0,31 m<sup>3</sup> | 6 kg - 13,2 lb

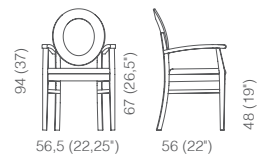

**gin cb bk**  
1 x box 0,37 m<sup>3</sup> | 8 kg - 17,6 lb

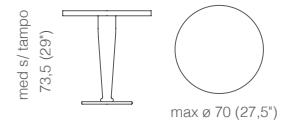

**cookie lisa**  
2 x box 0,14 m<sup>3</sup> | 28 kg - 61,74 lb

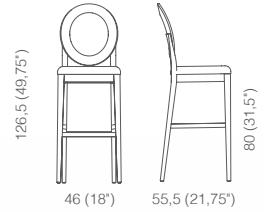

**gin est bar**  
1 x box 0,33 m<sup>3</sup> | 8,5 kg - 18,7 lb

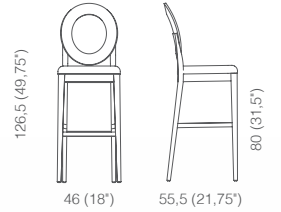

**gin bar**  
1 x box 0,33 m<sup>3</sup> | 8,5 kg - 18,7 lb



gin est bar



gin bar

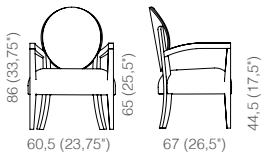

**mass 12**  
1 x box 0,33 m³ | 12,5 kg -27,6 lb

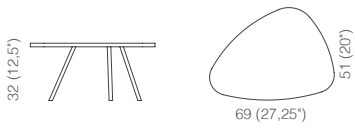

**blade h32**  
1 x box 0,15 m³ | 5 kg - 11 lb

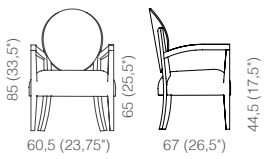

**mass 14**  
1 x box 0,33 m³ | 10,5 kg -23,1 lb

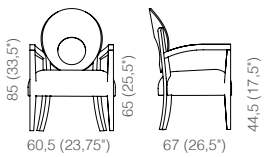

**mass 10**  
1 x box 0,33 m³ | 10,5 kg -23,1 lb



mass 12



blade h32



mass 10

mass 14





gaudi bx



gaudi bx

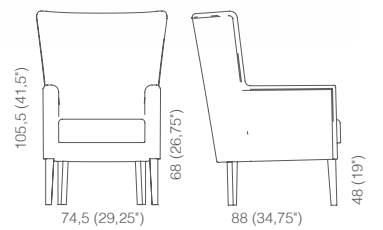

**gaudi bx**  
1 x box 0,68 m³ | 15,5 kg - 34,2 lb



wing



wing

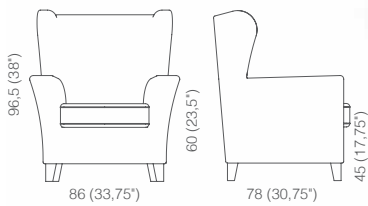

**wing**  
1 x box 0,81 m³ | 21 kg - 46,3 lb

Manufactured in solid beech wood, the Ome range is a dynamic collection with a strong right construction shaped bear to withstand the requirements of a contract environment.

*Fabricado em madeira de faia sólida, a gama Ome é uma coleção dinâmica com uma construção resistente, desenhada para suportar os requisitos de um ambiente de contract.*



ome ee cb bk

ome ee

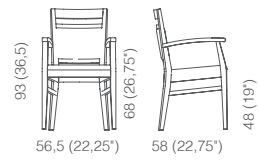

**ome ee cb bk**  
1 x box 0,37 m<sup>3</sup> | 10 kg - 22,1 lb

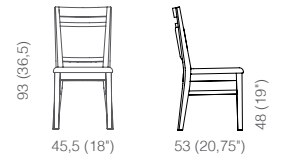

**ome ee**  
2 x box 0,31 m<sup>3</sup> | 8 kg - 17,6 lb



ome ee



ome ee cb bk



ome belas



ome belas

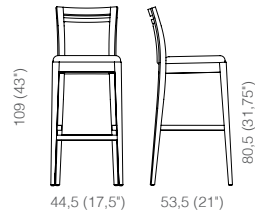

**cristiana est pro bar**  
1 x box 0,31 m³ | 7 kg - 15,4 lb

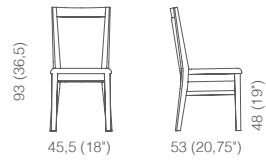

**ome est**  
2 x box 0,31 m³ | 8 kg - 17,6 lb

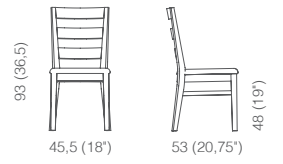

**ome belas**  
2 x box 0,31 m³ | 7,5 kg - 16,5 lb



ome est



ome est



cristiana est pro bar





sevilha zu 01 cb



sevilha zu 01

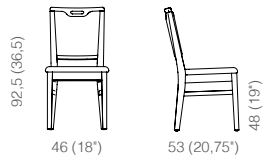

**sevilha zu 01**  
2 x box 0,31 m<sup>3</sup> | 7 kg - 15,4 lb

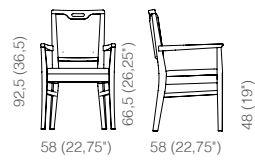

**sevilha zu 01 cb**  
1 x box 0,37 m<sup>3</sup> | 9 kg - 19,8 lb

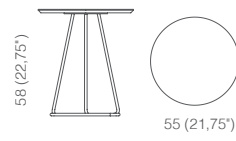

**gillo 2 h58**  
2 x box 0,23 m<sup>3</sup> | 6,3 kg - 13,9 lb

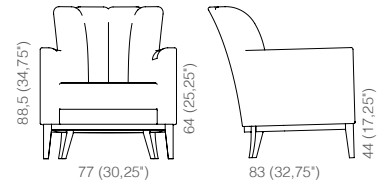

**madi**  
1 x box 0,55 m<sup>3</sup> | 19,5 kg - 43 lb



gillo 2



madi



madi

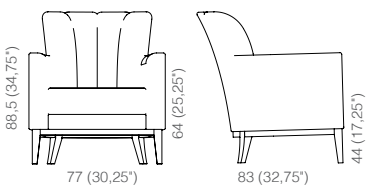

**madi**  
1 x box 0,55 m<sup>3</sup> | 19,5 kg - 43 lb





simple dan bar

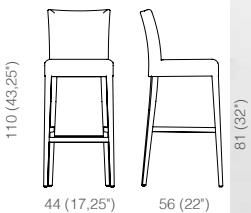

**simple dan bar**  
1 x box 0,31 m<sup>3</sup> | 7,5 kg - 16,5 lb

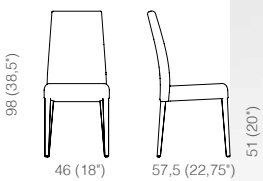

**simple dan emp**  
2 x box 0,36 m<sup>3</sup> | 7 kg - 15,4 lb



simple dan emp



simple dan



simple dan

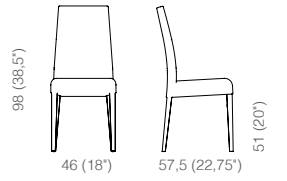

**simple dan**  
2 x box 0,31 m<sup>3</sup> | 6,5 kg - 14,3 lb



simple dan



simple dan





denise 01 cb



denise 01 cb

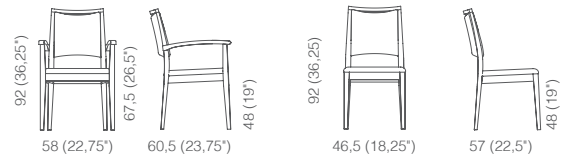

**denise 01 cb**  
2 x box 0,60 m<sup>3</sup> | 8 kg - 17,6 lb

**denise 01**  
2 x box 0,31 m<sup>3</sup> | 7 kg - 15,4 lb



denise 01



denise 01



denise 01

The unquestionable elegance of this classical design, Chesterfield collection is defined by its curved backrest and deep button back details provides a familiar presence to all types of environments.

*A inquestionável elegância deste design clássico, é definido pela sua costa curvada e detalhes de capitoné, que concede uma presença familiar a todos os tipos de ambiente.*





chesterfield

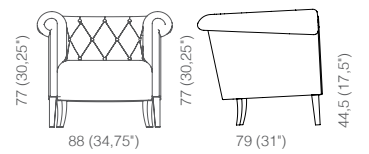

**chesterfield**  
1 x box 0,69 m<sup>3</sup> | 19,5 kg - 43 lb



denim



denim



denim

denim

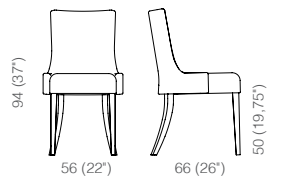

**denim**  
2 x box 0,44 m<sup>3</sup> | 10,5 kg - 23,1 lb



otto 01

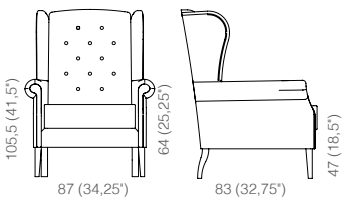

**otto 01**  
1 x box 0,55 m<sup>3</sup> | 22 kg - 48,5 lb





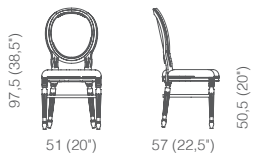

**louvre XVI tp**  
 2 x box 0,36 m<sup>3</sup> | 5,5 kg - 12,1 lb

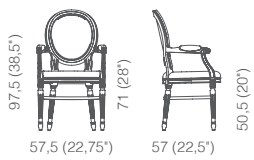

**louvre XVI tp cb**  
 1 x box 0,38 m<sup>3</sup> | 6,5 kg - 14,3 lb



louvre XVI tp



louvre XVI tp cb

louvre XVI tp

louvre XVI tp

With a wooden frame beautifully carved, Dima range offers a touch of class to any classic interior design project.

*Com uma estrutura de madeira lindamente esculpida, a gama Dima oferece um toque de classe para qualquer projeto de interiores de design clássico.*



dima cb



dima cb

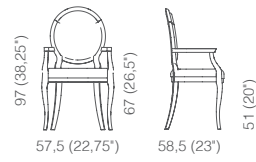

**dima cb**  
1 x box 0,37 m<sup>3</sup> | 7 kg - 15,4 lb

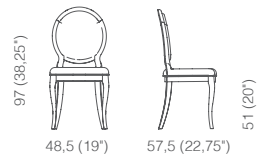

**dima**  
2 x box 0,36 m<sup>3</sup> | 6 kg - 13,2 lb



dima



chateau



chateau

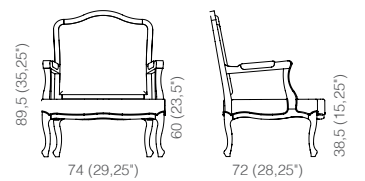

**chateau**  
1 x box 0,53 m<sup>3</sup> | 9 kg - 19,8 lb



louvre XVI tp



copper



louvre XVI tp cb



dakota

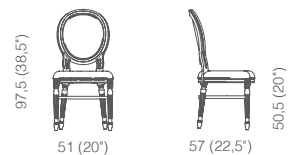

**louvre XVI tp**  
2 x box 0,36 m<sup>3</sup> | 5,5 kg - 12,1 lb

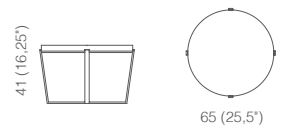

**copper h41**  
1 x box 0,23 m<sup>3</sup> | 12,5 kg - 27,6 lb

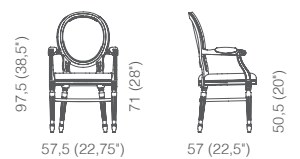

**louvre XVI tp cb**  
1 x box 0,38 m<sup>3</sup> | 6,5 kg - 14,3 lb

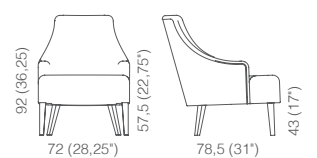

**dakota**  
1 x box 0,55 m<sup>3</sup> | 17 kg - 37,5 lb





meteor cb



meteor



**meteor cb**  
1 x box 0,42 m<sup>3</sup> | 7,5 kg - 16,5 lb

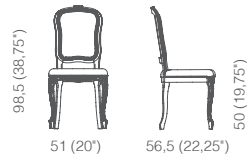

**meteor**  
2 x box 0,36 m<sup>3</sup> | 5,5 kg - 12,1 lb

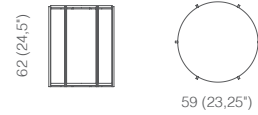

**geo wire h62**  
1 x box 0,27 m<sup>3</sup> | 10,3 kg - 22,7 lb

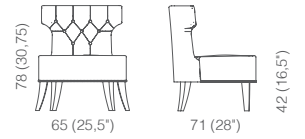

**roy**  
1 x box 0,46 m<sup>3</sup> | 11,5 kg - 25,4 lb



geo wire



roy

Glamorous lounge chair perfect to decorate any hotel interior or home interior. The high level of detail on the upholstery work gives it a luxurious and elegant look.

*Uma lounge com glamour, perfeita para decorar qualquer interior de hotel ou casa. O alto nível de detalhe e cuidado no trabalho de estofa dá-lhe um aspeto luxuoso e elegante.*



roy

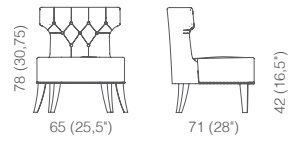

**roy**  
1 x box 0,46 m³ | 11,5 kg - 25,4 lb





meteor lounge



meteor lounge



meteor lounge

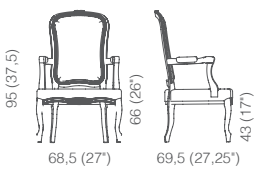

**meteor lounge**  
1 x box 0,42 m<sup>3</sup> | 7,5 kg - 16,5 lb



art 137

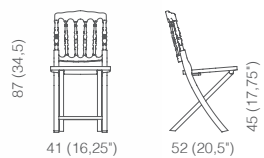

**art 137**  
5 x box 0,27 m<sup>3</sup> | 6 kg - 13,2 lb



art 137



art 137





camaleao go



camaleao go

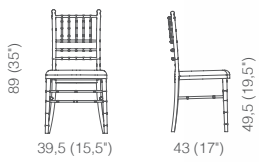

**camaleao go**  
2 x box 0,31 m<sup>2</sup> | 5 kg - 11 lb



minister maple

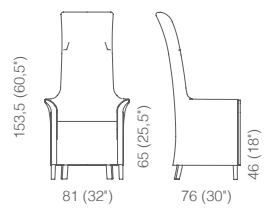

**minister maple**  
1 x box 1,13 m<sup>3</sup> | 20,5 kg - 45,2 lb

The design of this chair is marked by the over sized high back combined with the button and metal studs, making this chair a statement piece of furniture suitable for any classic and luxurious environment.

*O design desta cadeira é marcado pela costa extremamente alta, conjugada com botões e parafusos de metal, tornam esta cadeira uma statement piece perfeita para qualquer ambiente clássico e luxuoso.*



minister maple



lounge | *lounge*



# petra double

lounge | *lounge*

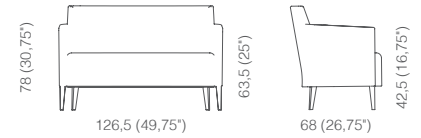

**petra double**  
1 x box 1,27 m<sup>3</sup> | 22 kg - 48,5 lb

# paty double

lounge | *lounge*

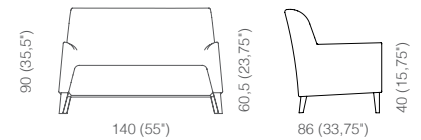

**paty double**  
1 x box 1,22 m<sup>3</sup> | 40 kg - 88,2 lb

# flower double

lounge | *lounge*

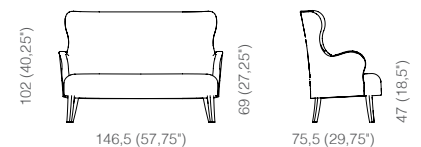

**flower double**  
1 x box 1,27 m<sup>3</sup> | 14,5 kg - 32 lb

# otto double

lounge | *lounge*

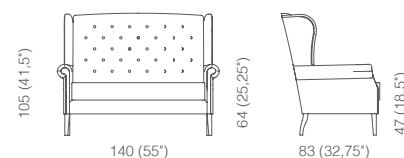

**otto double**  
1 x box 1,34 m<sup>3</sup> | 42 kg - 92,6 lb

# wing triple

lounge | *lounge*

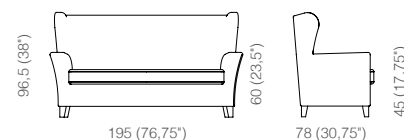

**wing triple**  
1 x box 1,43 m<sup>3</sup> | 50 kg - 110,2 lb

# chesterfield double

lounge | *lounge*



**chesterfield double**  
1 x box 1,15 m<sup>3</sup> | 37 kg - 81,6 lb





booths | *banquetas*



# chelsea



chelsea baq



chelsea high baq

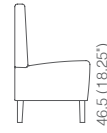
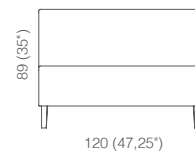

**chelsea baq**  
1 x box - 0,69 m<sup>3</sup>  
23 kg - 50,7 lb

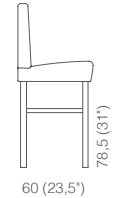
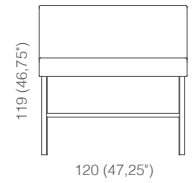

**chelsea high baq**  
1 x box - 0,80 m<sup>3</sup>  
22 kg - 48,5 lb

booths | banquetas

# dublin



dublin baq

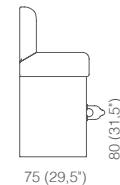
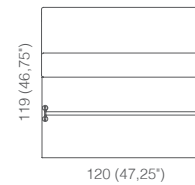

**dublin baq**  
1 x box - 1,00 m<sup>3</sup>  
56,5 kg - 124,6 lb

booths | banquetas

# yuma



yuma solid baq



yuma edge baq

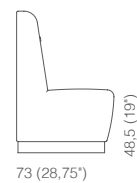
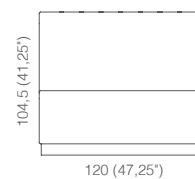

**yuma solid baq**  
1 x box - 0,90 m<sup>3</sup>  
37,5 kg - 82,7 lb

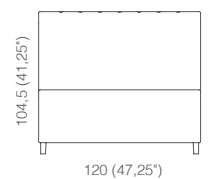

**yuma edge baq**  
1 x box - 0,91 m<sup>3</sup>  
37,5 kg - 82,7 lb

booths | banquetas

# yuma

booths | banquetas



yuma paris baq

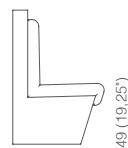
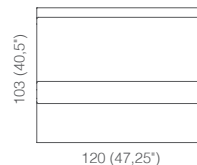

**yuma paris baq**  
1 x box - 1,02 m<sup>3</sup>  
66 kg - 145,5 lb

# frana

booths | banquetas



frana 01 baq



frana baq

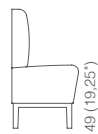
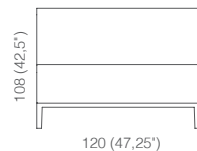

**frana 01 baq**  
1 x box - 0,84 m<sup>3</sup>  
27 kg - 59,5 lb

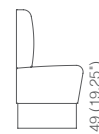
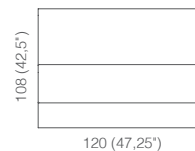

**frana baq**  
1 x box - 0,84 m<sup>3</sup>  
29 kg - 63,9 lb

# bilbao

booths | banquetas



bilbao baq

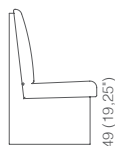
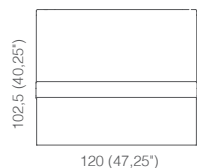

**bilbao baq**  
1 x box - 0,91 m<sup>3</sup>  
37,5 kg - 82,7 lb



dining tables  
metal tables  
coffee - side tables

*mesas de jantar*  
*mesas de metal*  
*mesas de apoio*



# smile 01 red

dining tables | *mesas de jantar*

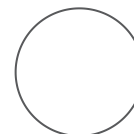

90 (35,5'')

**MD 015P**  
**smile 01 red**  
1 x box - 0,11 m<sup>3</sup>  
12,5 kg - 27,6 lb

# smile 01 quad

dining tables | *mesas de jantar*

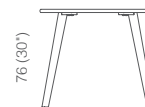

90 (35,5'')

**MQ 015P**  
**smile 01 quad**  
1 x box - 0,11 m<sup>3</sup>  
15,5 kg - 34,2 lb

# smile 01 rect

dining tables | *mesas de jantar*



120 (47,25'')

**MR 015P**  
**smile 01 rect**  
1 x box - 0,12 m<sup>3</sup>  
17 kg - 37,5 lb

# gomo dining

dining tables | *mesas de jantar*

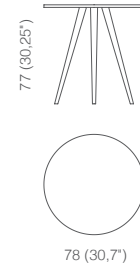

**MD 06T7**  
**gomo dining red**  
1 x box - 0,56 m<sup>3</sup>  
11 kg - 24,3 lb

# donasella quad

dining tables | *mesas de jantar*

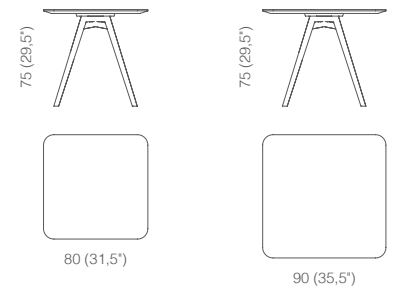

**MQ 07T4**  
**donasella quad**  
1 x box - 0,63 m<sup>3</sup>  
13,6 kg - 30 lb

**MQ 07T4**  
**donasella quad**  
1 x box - 0,63 m<sup>3</sup>  
16,8 kg - 37 lb

# donasella rect

dining tables | *mesas de jantar*

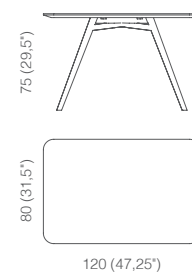

**MR 07T3**  
**donasella rect**  
1 x box - 0,73m<sup>3</sup>  
20,4 kg - 45 lb



# dona quad

dining tables | *mesas de jantar*

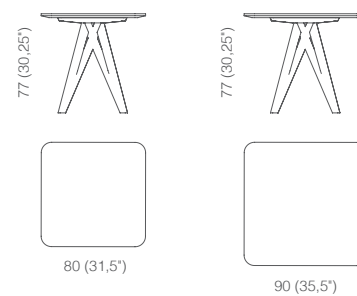

**MQ 07T1**  
**dona quad**  
1 x box - 0,63 m<sup>3</sup>  
15,9 kg - 35 lb

**MQ 07T1**  
**dona quad**  
1 x box - 0,63 m<sup>3</sup>  
19,3 kg - 42,5 lb

# dona rect

dining tables | *mesas de jantar*

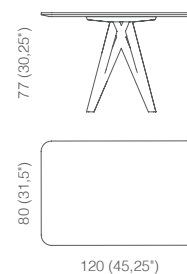

**MR 07T0**  
**dona rect**  
1 x box - 0,73 m<sup>3</sup>  
20,4 kg - 45 lb

# jar

dining tables | *mesas de jantar*

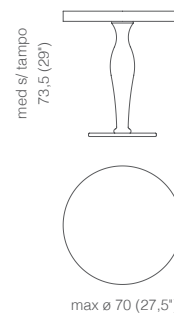

**ET OZ43**  
**jar**  
1 x box - 0,14 m<sup>3</sup>  
28 kg - 61,75 lb

# cookie lisa



dining tables | *mesas de jantar*

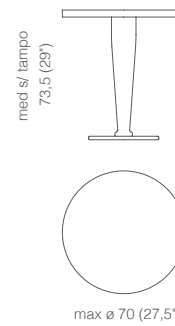

**ET 053V**  
**cookie lisa**  
1 x box - 0,14 m<sup>3</sup>  
28 kg - 61,74 lb

# norma



# norma tri



dining tables | *mesas de jantar*

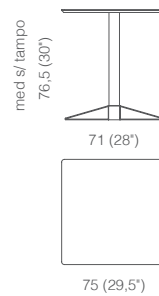

**ET 05T6**  
**norma h76,5**  
1 x box - 0,14 m<sup>3</sup>  
15 kg - 33,1 lb

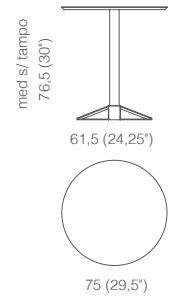

**ET 05T7**  
**norma tri h76,5**  
1 x box - 0,14 m<sup>3</sup>  
19,8 kg - 43,6 lb

# bern



dining tables | *mesas de jantar*

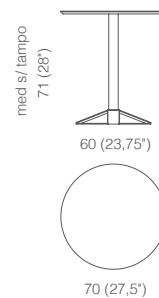

**MD 0Z68**  
**bern**  
1 x box - 0,28 m<sup>3</sup>  
20 kg - 48,50 lb

# tess rect (pe k)

dining tables | *mesas de jantar*

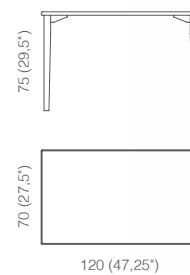

**MR 044V**  
**tess rect pe k**  
1 x box - 0,11 m<sup>3</sup>  
22 kg - 48,5 lb

**MR 09C2**  
available with square leg  
*disponível com pé quadrado*

# tess red (pe k)

dining tables | *mesas de jantar*

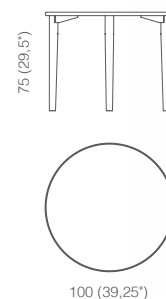

**MD 044V**  
**tess red pe k**  
1 x box - 0,13 m<sup>3</sup>  
17 kg - 37,5 lb

**MD 09C2**  
available with square leg  
*disponível com pé quadrado*

# tess quad (pe k)

dining tables | *mesas de jantar*

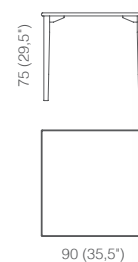

**MQ 08B6**  
**tess quad pe k**  
1 x box - 0,11 m<sup>3</sup>  
20 kg - 44,1 lb

**MQ 044V**  
available with square leg  
*disponível com pé quadrado*

# porto quad

dining tables | *mesas de jantar*

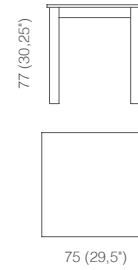

**MQ 0002**  
**porto quad**  
1 x box - 0,07 m<sup>3</sup>  
21,5 kg - 47,4 lb

# porto eco rect

dining tables | *mesas de jantar*

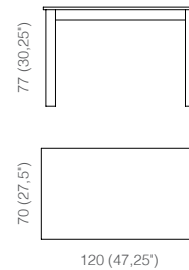

**MR 0290**  
**porto eco rect**  
1 x box - 0,11 m<sup>3</sup>  
24 kg - 52,9 lb

# porto eco quad

dining tables | *mesas de jantar*

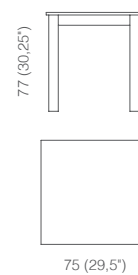

**MQ 0290**  
**porto eco quad 750h750**  
1 x box - 0,07 m<sup>3</sup>  
21,5 kg - 47,4 lb

# pfill 110



metal tables | *mesas de metal*

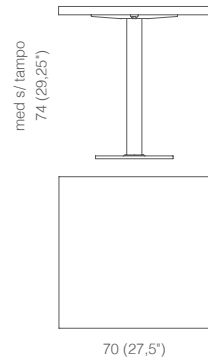

**ET 0327**  
**pfill 110**  
1 x box - 0,04 m<sup>3</sup>  
13 kg - 28,7 lb

# pfill 4490



metal tables | *mesas de metal*

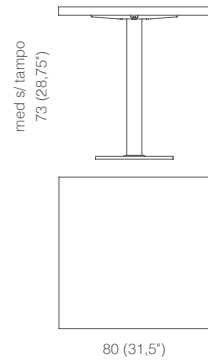

**ET 006Y**  
**pfill 4490**  
1 x box - 0,06 m<sup>3</sup>  
14 kg - 30,9 lb

# pfill 405



metal tables | *mesas de metal*

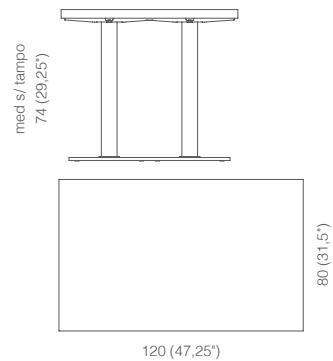

**ET 0405**  
**pfill 405**  
1 x box - 0,05 m<sup>3</sup>  
28 kg - 61,7 lb

# pfill 430



metal tables | *mesas de metal*

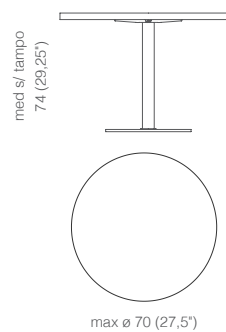

**ET 0430**  
**pfill 430**  
1 x box - 0,04 m<sup>3</sup>  
13 kg - 28,7 lb

# pfill 430 bar



metal tables | *mesas de metal*

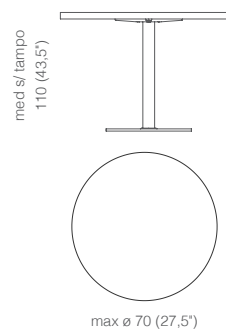

**ET 0428**  
**pfill 430 bar**  
1 x box - 0,20 m<sup>3</sup>  
24 kg - 52,92 lb

# pfill 109



metal tables | *mesas de metal*

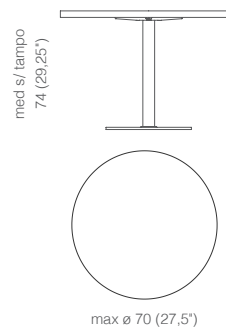

**ET 0109**  
**pfill 109**  
1 x box - 0,04 m<sup>3</sup>  
10 kg - 22,1 lb

# pfill 111



metal tables | *mesas de metal*

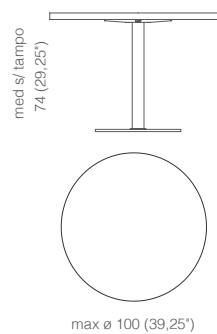

**ET 0111**  
**pfill 111**  
1 x box - 0,06 m<sup>3</sup>  
14 kg - 30,9 lb

# pfill 431



metal tables | *mesas de metal*

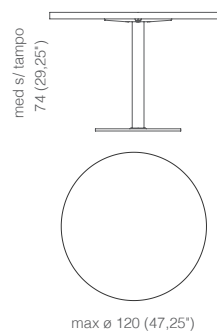

**ET 0431**  
**pfill 431**  
1 x box - 0,06 m<sup>3</sup>  
13 kg - 28,7 lb

# pfill 400 q



metal tables | *mesas de metal*

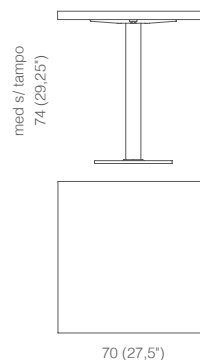

**ET 0295**  
**pfill 400 Q**  
1 x box - 0,04 m<sup>3</sup>  
24 kg - 52,9 lb

# pfill 400 bq

metal tables | *mesas de metal*

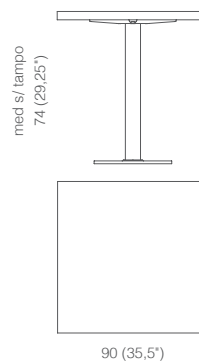

**ET 0343**  
**pfill 400 bq**  
1 x box - 0,07 m<sup>3</sup>  
14 kg - 30,9 lb

# pfill 405 s

metal tables | *mesas de metal*

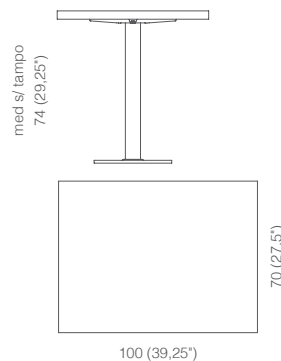

**ET 0R48**  
**pfill 405 s**  
1 x box - 0,04 m<sup>3</sup>  
24 kg - 52,9 lb



# twist

coffee - side tables | *mesas de apoio*

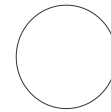

max ø 80 (30,5")

**MD 0Z64**  
**twist**  
1 x box - 0,19 m<sup>3</sup>  
12 kg - 26.5 lb

# gomo side oval

coffee - side tables | *mesas de apoio*



100 (39,25")

**MD 06T8**  
**gomo side oval h45**  
1 x box - 0,34 m<sup>3</sup>  
11,5 kg - 25,4 lb

# gomo side red

coffee - side tables | *mesas de apoio*



184 gomo side red h55



gomo side red h60



50 (19,75")

**MD 06T5**  
**gomo side red h55**  
1 x box - 0,18 m<sup>3</sup>  
5,3 kg - 11,7 lb

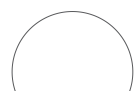

100 (39,25")

**MD 06T6**  
**gomo side red h60**  
1 x box - 0,71 m<sup>3</sup>  
10 kg - 22,1lb

# carter sp100

coffee - side tables | *mesas de apoio*

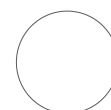

80 (31,5")

**MD 0Z75**  
**carter sp100**  
1 x box - 0,24 m<sup>3</sup>  
19 kg - 41,9 lb

# carter 200/ 300

coffee - side tables | *mesas de apoio*



carter 200



carter 300



60 (23,5")

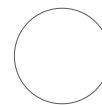

60 (23,5")

**MD 0Z77**  
**carter 200**  
1 x box - 0,24 m<sup>3</sup>  
10,5 kg - 23,1 lb

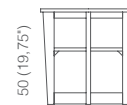

50 (19,75")

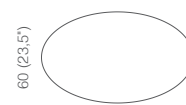

60 (23,5")

100 (39,25")

**MO 037A**  
**carter 300**  
1 x box - 0,32 m<sup>3</sup>  
16 kg - 35,27 lb

# smile 01 low

coffee - side tables | *mesas de apoio*



46 (18")

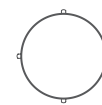

60 (23,5")

**MD 010P**  
**smile 01 low**  
1 x box - 0,06 m<sup>3</sup>  
10 kg - 22,1 lb

# dante

coffee - side tables | *mesas de apoio*

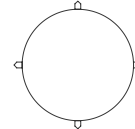
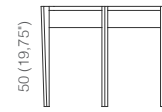

**MD 028V**  
**dante**  
1 x box - 0,10 m<sup>3</sup>  
6,5 kg - 14,3 lb

# copper

coffee - side tables | *mesas de apoio*



copper h41



copper h51



copper h61

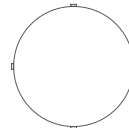
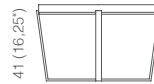

**MD 05T1**  
**copper h41**  
1 x box - 0,23 m<sup>3</sup>  
12,5 kg - 27,6 lb

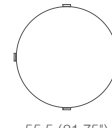
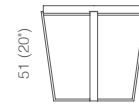

**MD 05T0**  
**copper h51**  
1 x box - 0,20 m<sup>3</sup>  
10,5 kg - 23,1 lb

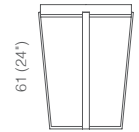

**MD 04T9**  
**copper h61**  
1 x box - 0,17 m<sup>3</sup>  
8,1 kg - 17,9 lb

# dum

coffee - side tables | *mesas de apoio*



186 dum h43,5



dum h59

med s/ tampo  
43,5 (17,25")



50 (19,75")

**ET 06T3**  
**dum metal h43,5**  
1 x box - 0,15 m<sup>3</sup>  
6,1 kg - 13,4 lb

med s/ tampo  
59 (23,25")

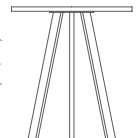

55 (21,75")

**ET 06T4**  
**dum metal h59**  
1 x box - 0,23 m<sup>3</sup>  
7,5 kg - 16,5 lb

# blade h38



coffee - side tables | *mesas de apoio*

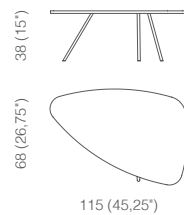

**MO 08P4**  
**blade h38**  
1 x box - 0,37 m<sup>3</sup>  
10,2 kg - 22,5 lb

# blade h45



coffee - side tables | *mesas de apoio*

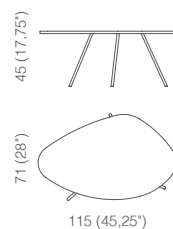

**MO 08P5**  
**blade h45**  
1 x box - 0,46 m<sup>3</sup>  
10,6 kg - 23,4 lb

# blade h32



coffee - side tables | *mesas de apoio*

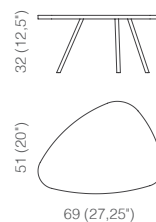

**MO 08P3**  
**blade h32**  
1 x box - 0,15 m<sup>3</sup>  
5 kg - 11 lb

# gillo 3

coffee - side tables | *mesas de apoio*

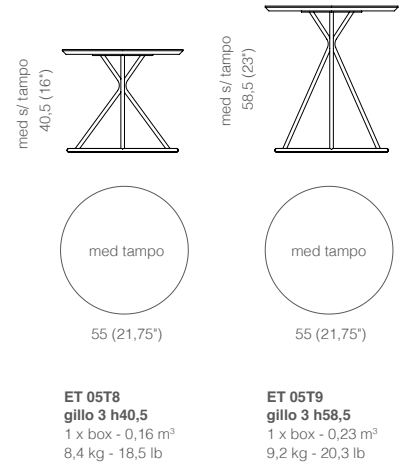

# gillo 2

coffee - side tables | *mesas de apoio*

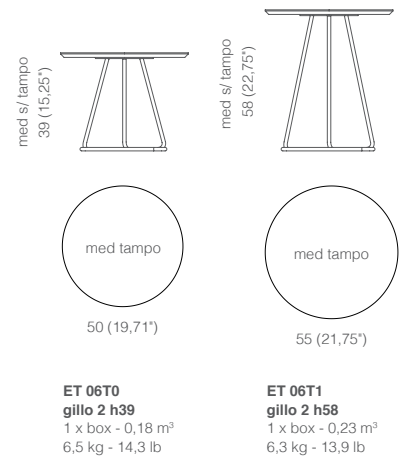

# marbel

coffee - side tables | *mesas de apoio*

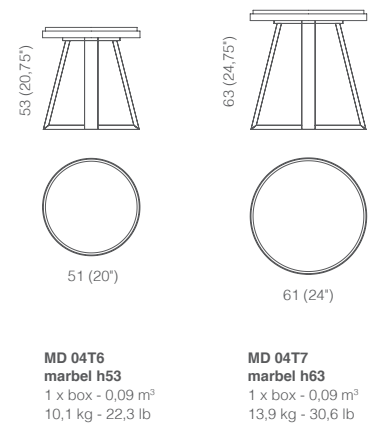

188 marbel h53

marbel h63

# kactus

coffee - side tables | *mesas de apoio*



kactus h52



kactus h60

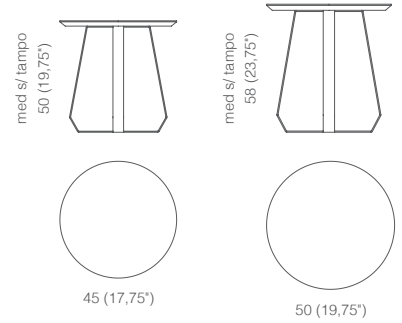

**MD 06T2**  
**kactus h52**  
1 x box - 0,14 m<sup>3</sup>  
10 kg - 22,1 lb

**MD 08P2**  
**kactus h60**  
1 x box - 0,20 m<sup>3</sup>  
10 kg - 22,1 lb

# geo

coffee - side tables | *mesas de apoio*



geo h44



geo h51



geo h76

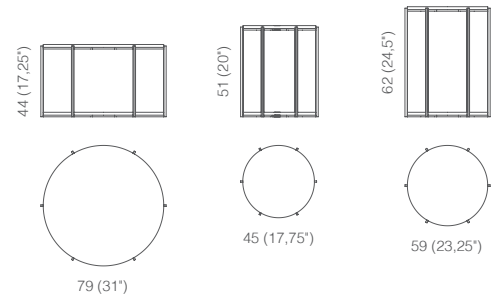

**MD 08P0**  
**geo h44**  
1 x box - 0,36 m<sup>3</sup>  
16,4 kg - 36,2 lb

**MD 05T2**  
**geo h51**  
1 x box - 0,14 m<sup>3</sup>  
7,8 kg - 17,2 lb

**MD 08P1**  
**geo h76**  
1 x box - 0,27 m<sup>3</sup>  
10,3 kg - 22,7 lb

# geo wire

coffee - side tables | *mesas de apoio*



geo hire h44



geo hire h51



geo hire h62

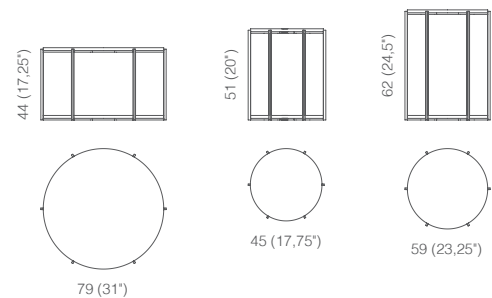

**MD 05T5**  
**geo wire h44**  
1 x box - 0,36 m<sup>3</sup>  
16,4 kg - 36,2 lb

**MD 05T3**  
**geo wire h51**  
1 x box - 0,14 m<sup>3</sup>  
7,8 kg - 17,2 lb

**MD 05T4**  
**geo wire h62**  
1 x box - 0,27 m<sup>3</sup>  
10,3 kg - 22,7 lb

# bergamo bx

coffee - side tables | *mesas de apoio*

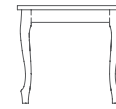
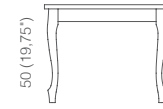

60 (23,5')

**MQ 036A**  
**bergamo bx**  
1 x box - 0,18 m<sup>3</sup>  
7 kg - 15,43 lb

# wheel

trolley | *carrinho*

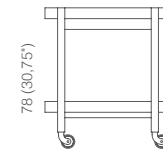

70 (27,5')

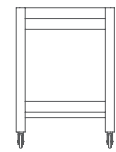

55 (21,75')

**MD 06T9**  
**wheel**  
1 x box - 0,37 m<sup>3</sup>  
13,8 kg - 30,4 lb

## TABLE TOPS TAMPOS

### VENEERED MDF WITH EDGE

mdf folheado c/orla  
mdf plaqué avec chant  
mdf furniert mit rand  
dm chapado con canto

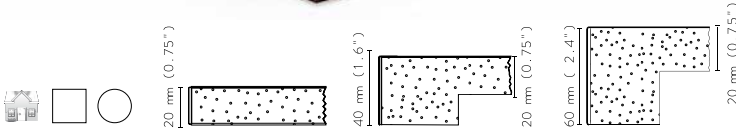

Available Edges | Cantos Disponíveis | Chants Disponibles | verfügbare Kante | Cantos Disponibles



COD. T0131

**veneered edge** straight corner | orla folheada canto reto | chant plaqué bord droit | furnierten Rand gerade Kanten canto chapado borde recto



COD. T0150

**solid wood edge** straight corner | orla maciça canto reto | chant massif bord droit | massiven Rand gerade Kanten canto mader maciza borde recto

### LAMINATE WITHOUT EDGE

termolaminado s/orla | stratifié sans chant | thermolaminat ohne rand  
laminado sin canto

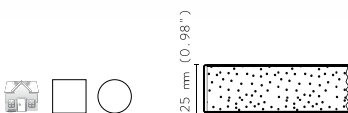

Available Edges | Cantos Disponíveis | Chants Disponibles | verfügbare Kante | Cantos Disponibles



COD. T1976

**Plywood rounded edge nr4**, rounded corner  
Contraplacado orla boleada no 4 canto boleado  
Contreplaqué Chant arrondi nr4, bord arrondi  
Sperrholz runder Rand Nr.4, abgerundete Kanten  
Contrachapado canto redondo nr 4, borde redondo

### LAMINATED CHIPBOARD WITH EDGE

aglomerado termolaminado c/orla  
aggloméré stratifié avec chant  
laminierte spanplatte mit rand  
aglomerado laminado con canto

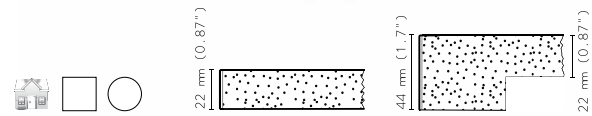

Available Edges | Cantos Disponíveis | Chants Disponibles | verfügbare Kante | Cantos Disponibles



COD. T0812

**solid round edge**, round corner | orla boleada maciça canto boleado | chant massif arrondi, bord arrondi | runder Rand massiv, abgerundete Kante canto redondo maciza, borde redondo



COD. T0122

**solid edge**, straight corner | orla maciça canto reto | chant massif, bord droit | Rand massiv, gerade Kante | canto maciza, borde recto



COD. T0855

**PVC 2mm (0.8") edge**, straight corner | orla PVC 2mm canto reto | chant PVC 2mm bord droit | PVC-Rand 2mm, gerade Kanten canto PVC 2mm borde recto

### MELAMINE FACED CHIPBOARD WITH EDGE

aglomerado melamina c/orla | aggloméré melaminé avec chant  
spanplatte melamin mit rand | aglomerado melamina con canto

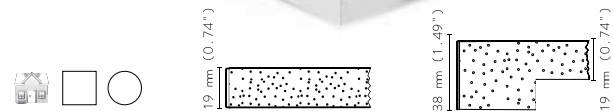

Available Edges | Cantos Disponíveis | Chants Disponibles | verfügbare Kante | Cantos Disponibles



COD. T0124

**PVC 2mm (0.8") edge**, straight corner  
orla PVC 2mm canto reto  
chant PVC 2mm bord droit  
PVC-Rand 2mm, gerade Kanten  
canto PVC 2mm borde recto / 2毫米PVC封边





finishes  
*acabamentos*



# laminates | *laminados*

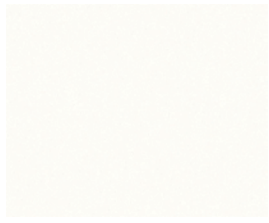

L0108 (B070 FA)



L0043 (B099 FA)



L0124 (N005 ROC)



L0125 (4573)



L0054 (C132 GRAIN)



L0126 (A095 ROC)



L0127 (C105 EXM)



L0039 (N057 EXW)



L0111 (C047FA)



L0044 (E009 FA)



L0057 (C098 FA)



L0038 (C092 FA)

# melamine | *melamina*

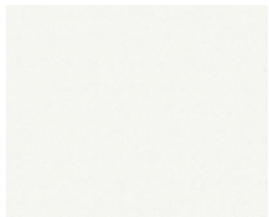

T0309 (W908 ST2)



T0310 (F274 ST9)

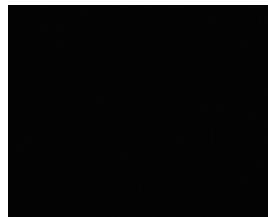

T0285 (U999 ST2)



T0311 (K005)



T0312 (K007)



T0280 (H1137 ST11)



T0313 (4298)



T0314 (4599)



T0315 (K011)



T0287 (H1334 ST9)



T0316 (K003)



T0317 (K009)

## valchromat | *valchromat*



**T2054**  
Yellow  
Amarelo



**T2055**  
Violet  
Violeta



**T2056**  
Green  
Verde



**T2057**  
Black  
Preto



**T2058**  
Blue  
Azul



**T2059**  
Dark Grey  
Cinza Escuro

## tables structures | *estruturas de mesa* iron finishes | *acabamentos de ferro*



**T0005**  
Black  
Preto  
Noir  
Schwars Epoxy  
Negro



**T0010**  
Silver  
Cinza Prata  
Gris Argent  
Grau/Silber  
Gris Plata



**T0043**  
Gold  
Dourado  
Doré  
Gold  
Dorado



**T0224**  
White  
Branco  
Blanc  
Weiss  
Blanco



 Stain Colors with extra cost • Cores com custo extra • Couleurs à coût supplémentaire • Beiztöne mit Aufpreis • Colores con costo adicional

## Stainless Steel Finishes | *acabamentos de inox*



**T0113**  
Brushed Stainless Steel  
Inox Escovado  
Inox Brossé  
Gebürstetes Edelstahl  
Inox Cepillado

## beech wood | *faia*



**C09**  
STEAMED/ VAPORIZADA/ VAPORISÉ/  
GEDÄMPFT/ VAPORIZADA



**C63**  
LIGHT CHERRY/ CEREJEIRA CLARA/  
MEURISIER CLAIR/ KIRSCHHE HELL/ CEREZA  
CLARA



**C113**  
HONEY STAIN/ PINHO MEL/ PINE MIEL/ KIEFER  
HONIG/ PINO MIEL



**C26**  
WALNUT COLOR/ COR NOGUEIRA/ NOYER  
COULEUR/ FARBE WALNUS/ COLOR NOGAL



**C928**  
DOVE GREY/ DOVE CINZA/ DOVE GRIS/ DOVE  
GRAU/ DOVE GRIS



**C20**  
ALASKA GREY/ CINZA ALASKA/ GRIS ALASKA  
ALASKA GRAU/ ALASKA GRIS



**C17**  
PARIS GRAY BRUSHED/ CINZA PARIS  
ESCOVADO/ GRIS PARIS BROSSE/ GRAU  
PARIS GEBÜRSTET/ GRIS PARIS CEPILLADO



**C118**  
GREY/ CINZA/ GRIS/ GRAU/ GRIS



**C65**  
MOHOGANY/ MOGNO/ ACAJOU/ MAHAGONI/  
CAOBA



**C31**  
BROWN WENGUE/ WENGUE CASTANHO/  
WENGUE MARRON/ WENGÉ BRAUN/ WENGUE  
CASTAÑO



**C32**  
DARK WENGUE/ WENGUE ESCURO/ WENGUE  
FONCÉ/ WENGÉ DUNKEL/ WENGUE NEGRO



**C46**  
BLACK WENGUE/ WENGUE NEGRO/ WENGUE  
NOIR/ SCHWARZ WENGÉ / WENGUE NEGRO

## ash wood | *freixo*



**C44**  
OAK COLOR / COR CARVALHO/ COULEUR  
CHÊNE/ EICHE FARBE/ COLOR DE ROBLE



**C112**  
WALNUT COLOR/ COR NOGUEIRA/ NOYER  
COULEUR/ FARBE WALNUS/ COLOR NOGAL



**C704**  
DARK GREY/ CINZA ESCURO/ GRIS FONCÉ/  
DUNKEL GRAU/ GRIS OSCURO



**C17**  
PARIS GRAY BRUSHED/ CINZA PARIS  
ESCOVADO/ GRIS PARIS BROSSE/ GRAU  
PARIS GERÜRSTET/ GRIS PARIS CEPILLADO

# beech wood | *faia*



**C19**  
NATURAL / NATURAL / NATUREL / NATUR /  
NATURAL



**C22**  
STEAMED / VAPORIZADA / VAPORISÉ /  
GEDÄMPFT / VAPORIZADA

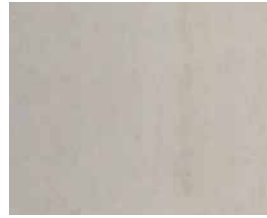

**C927**  
IVORY GRAY / CINZA IVORY / GRIS IVORY /  
IVORY GRAU / GRIS IVORY

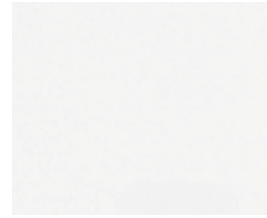

**C174**  
WHITE PAINTED / BRANCO PINTADO / PAINT  
BLANC / WEISS MATT LACKIERT / BLANCO  
PINTADO



**C926**  
LIGHT LINEN / LINEN CLARO / LINEN CLAIR /  
LEINEN HELL / LINEN CLARO



**C18**  
BEIGE / BEGE



**C16**  
LUANDA BEIGE / BEGE LUANDA



**C42**  
MATT GREYISH GREEN LACQUERED / OLIVE  
ESCURO LACADO / LAQUÉ GRIS OLIVE FONCE  
MATE / GRAUGRÜN DUNKEL MATT LACKIERT /  
LACADO GRIS OLIVA ESCURO MATE

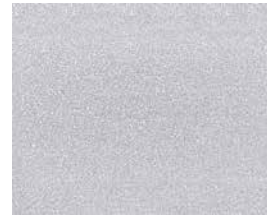

**C85**  
SILVER / PRATA / ARGENTÉ / SILBER /  
PLATEADO



**C68**  
ANTIQUÉ SILVER / PRATA VELHO / VIEUX  
ARGENTÉ / ANTIK SILBER / PLATEADO VIEJO



**C593**  
BURNISHED GOLD / DOURADO TEXTURADO /  
DORÉ TEXTURE / GOLD TEXTUR / ORO  
BRUNIDO



**C69**  
ANTIQUÉ BURNISHED GOLD / DOURADO  
VELHO TEXTURADO / VIEUX DORÉ TEXTURE /  
ANTIQUÉ TEXTURGOLD / DORADO VIEJO

# ash wood | *freixo*



**C27**  
NATURAL / NATURAL / NATUREL / NATUR /  
NATURAL



**C832**  
WHITE BRUSHED / BRANCO ESCOVADO /  
BLANC BROSSE / WEISS GEBÜRSTET /  
BLANCO CEPILLADO



**C28**  
STEAMED / VAPORIZADA / VAPORISÉ /  
GEDÄMPFT / VAPORIZADA



**C929**  
CHARCOAL GREY / CINZA CHARCOAL / GRIS  
CHARCOAL / CHARCOAL GRAU / CHARCOAL  
GRIS



**C924**  
BLUE ANILINE / ANILINE AZUL / BLEU  
ANILINE / BLAU ANILINE / AZUL ANILINE



**C925**  
GREEN ANILINE / ANILINE VERDE / VERT  
ANILINE / GRÜN ANILINE / VERDE ANILINE



**C922**  
GREY ANILINE / ANILINE CINZA / GRIS ANILINE  
/ GRAU ANILINE / GRIS ANILINE



**C923**  
RED ANILINE / ANILINE VERMELHO / ROUGE  
ANILINE / ROT ANILINE / ROJO ANILINE

# special colors

## MAINTENANCE AND CLEANING ADVICE

### CONSELHOS DE MANUTENÇÃO E LIMPEZA

#### Wood and Veneer | Madeira e Folheado

- EN**
- WOOD AND VENEER ARE AFFECTED BY LIGHT AND SOURCES OF HEAT. FOR THE FIRST 6–8 WEEKS, WHEN THE ITEM IS ABSORBING THE SURROUNDING LIGHT, KEEP THE SURFACES CLEAR OF ANY OBJECTS TO AVOID PERMANENT MARKS AND CIRCLES.
  - PROTECT WOOD AND VENEER FROM DIRECT SUNLIGHT TO PREVENT COLOUR FADING.
  - OUR FURNITURE IS DESIGNED TO BE USED INDOORS UNDER STANDARD CONDITIONS WITH A RELATIVE HUMIDITY BETWEEN 25 AND 60% AND A TEMPERATURE BETWEEN 18 AND 24° C. OTHERWISE THIS WILL HAVE NEGATIVE EFFECTS ON THE FURNITURE AND CAN RESULT IN DISTORTIONS IN THE FORM OF WOOD.
  - CHANGES IN TEXTURE, MINOR DEVIATIONS IN COLOUR AND NATURAL GROWTH DEFECTS ARE NOT CONSIDERED FAILURES, THEY ONLY PROVE THE GENUINE NATURE OF WOOD. AS A NATURAL ELEMENT, THE WOOD IS ALWAYS REACTING TO THE SURROUNDING ENVIRONMENT. THIS MAY RESULT IN SMALL CRACKS IN THE PAINT OR IN A SLIGHT PENETRATION OF THE WOODEN STRUCTURE ON THE SURFACE DURING THE LIFETIME OF THE PRODUCT. THIS SHOULD NOT BE CONSIDERED AS A DEFECT BUT NATURAL MATERIAL.
  - WATER MUST BE USED IN SMALL QUANTITIES AND ONLY IN THE FORM OF A DAMP CLOTH. AFTER WIPING, ALWAYS USE A DRY CLOTH.
  - WOOD AND VENEER ARE VERY SENSITIVE TO LIQUIDS. WIPE UP SPILLED LIQUIDS IMMEDIATELY.
  - ALWAYS TRY TO REMOVE STAINS WITH THE MILDDEST CLEANING MATERIALS. A SUITABLE SOAP SOLUTION IS MADE FROM ¼ DL SOAP POWDER TO 1 LITRE OF WARM WATER.
  - NEVER USE THE AGENTS CONTAINING BENZENE AND OTHER SOLVENTS.
  - ALL WOOD STAINS MATCH TO THE TYPE OF WOOD TO WHICH THEY HAVE BEEN APPLIED. OTHER WOODS WILL HAVE DIFFERENT STAINS AND/OR TEXTURES
- PT**
- A MADEIRA E O FOLHEADO SÃO AFECTADOS PELA LUZ E PELO CALOR. DURANTE AS PRIMEIRAS 6 A 8 SEMANAS, QUANDO O PRODUTO ESTIVER A ABSORVER INICIALMENTE A LUZ CIRCUNDANTE, MANTENHA AS SUPERFÍCIES LIVRES DE QUAISQUER OBJECTOS PARA EVITAR MARCAS E CÍRCULOS PERMANENTES.
  - PROTEJA A MADEIRA E O FOLHEADO DA LUZ SOLAR DIRECTA PARA PREVENIR O ESBATIMENTO DAS CORES.
  - O MOBILIÁRIO É DESENHADO PARA SER USADO NO INTERIOR EM CONDIÇÕES STANDARD, COM UMA HUMIDADE RELATIVA ENTRE 25 E 60% E UMA TEMPERATURA ENTRE 18 E 24°C. CASO CONTRÁRIO TERÁ EFEITOS NEGATIVOS NO MOBILIÁRIO E PODE RESULTAR EM DISTORÇÕES NA FORMA DA MADEIRA.
  - MUDANÇAS NA TEXTURA, DESVIOS MENORES NA COR E DEFEITOS NATURAIS DE CRESCIMENTO NÃO SÃO CONSIDERADOS COMO FALHAS, PELO CONTRÁRIO, COMPROVAM A NATUREZA GENUÍNA DA MADEIRA. SENDO UM MATERIAL NATURAL, A MADEIRA REAGE PERMANENTEMENTE AO AMBIENTE ENVOLVENTE. ESTA REAÇÃO PODE CONSISTIR EM PEQUENAS FENDAS NA PINTURA OU NUMA LIGEIRA PENETRAÇÃO DESTA NA ESTRUTURA DA MADEIRA DURANTE O CICLO DE VIDA DO PRODUTO. ISTO NÃO DEVE SER CONSIDERADO UM DEFEITO DE FABRICO, MAS UMA CONSEQUÊNCIA DA CONDIÇÃO NATURAL DA MADEIRA.
  - SÓ DEVE USAR-SE ÁGUA EM PEQUENAS DOSES E APENAS NUM PANO HÚMIDO. DEPOIS DE LIMPAR, USE SEMPRE UM PANO SECO.
  - A MADEIRA E O FOLHEADO SÃO SENSÍVEIS AOS LÍQUIDOS. LIMPE IMEDIATAMENTE LÍQUIDOS DERRAMADOS.
  - TENTE SEMPRE REMOVER MANCHAS USANDO O MATERIAL DE LIMPEZA MAIS SUAVE. UMA SOLUÇÃO DE SABÃO ADEQUADA É CONSTITUÍDA POR ¼DL DE SABÃO EM PÓ POR 1 LITRO ÁGUA QUENTE.
  - NUNCA UTILIZAR PRODUTOS QUE CONTENHAM BENZENO OU OUTROS SOLVENTES.
  - TODAS AS CORES DE ACABAMENTOS CORRESPONDEM AO TIPO DE MADEIRA EM QUE FORAM APLICADAS. EM OUTRAS MADEIRAS TERÃO DIFERENTES TONALIDADE E/OU TEXTURAS.

> **THE COLOUR SAMPLES CAN BE CHANGED WITHOUT PRIOR NOTICE, FOR TECHNICAL REASONS OR DUE TO PRODUCTION QUALITY MODIFICATIONS. THE COLOURS AND TONES ARE MERELY INDICATIVES. WE WAIVE ALL RESPONSIBILITY FOR COLOUR CHANGE WHEN EXPOSED TO THE SUNLIGHT //**

> AS AMOSTRAS DE CORES PODEM SER ALTERADAS SEM AVISO PRÉVIO, POR MOTIVOS TÉCNICOS OU DEVIDO A MODIFICAÇÕES QUALITATIVAS DE PRODUÇÃO. AS TONALIDADES SÃO MERAMENTE INDICATIVAS. DECLINAMOS QUALQUER RESPONSABILIDADE NA ALTERAÇÃO DA COR QUANDO EXPOSTA À LUZ SOLAR. //

> LES ÉCHANTILLONS PEUVENT ÊTRE MODIFIÉS SANS PRÉAVIS, POUR RAISON TECHNIQUE OU DÙ À DES MODIFICATIONS QUALITATIVES DE PRODUCTION. LES COULEURS ET TONALITÉS SONT PUREMENT INDICATIVES. NOUS DÉCLINONS TOUTE RÉSPONSABILITÉ DE MODIFICATION DE TEINTE LORSQUE EXPOSÉ À LA LUMIÈRE SOLAIRE. //

> DIE FARBMASTER KÖNNEN OHNE VORHERIGE ANKÜNDIGUNG, AUS TECHNISCHEN GRÜNDEN ODER INFOLGE QUALITATIVE VERBESSERUNG DER PRODUKTION, GEÄNDERT WERDEN. DIE TONARTEN DIENEN LEDIGLICH ALS RICHTLINIEN. WIR ÜBERNEHMEN KEINE VERANTWORTUNG ODER HAFTUNG FÜR ÄNDERUNGEN AM BEIZTON BEI SONNENEINSTRHLUNG. //

> LAS MUESTRAS DE COLORES PUEDEN CAMBIAR, SIN PREVIO AVISO, POR MOTIVOS TÉCNICOS Ó DEBIDO A MODIFICACIONES DE PRODUCCIÓN RELATIVAS A LA CALIDADE. LOS COLORES Y TONALIDADES SON MERAMENTE ORIENTATIVOS. RENUNCIAREMOS A TODA LA RESPONSABILIDAD DE CAMBIO DE COLOR CUANDO SE EXPONE A LA LUZ SOLAR. //



**STAIN COLORS WITH EXTRA COST • CORES COM CUSTO EXTRA • COULEURS À COÛT SUPPLÉMENTAIRE • BEIZTÖNE MIT AUFPREIS  
COLORES CON COSTO ADICIONAL**

fabric  
*tecidos*





# madeira

# cat.W

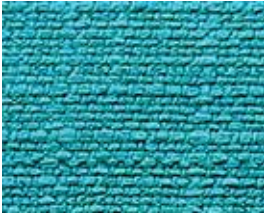

W0152



W0167



W0174



W0175



W0245



W0246



W0247



W0248

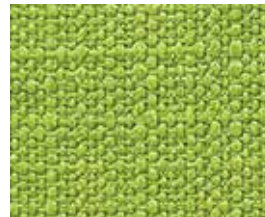

W0249

**composition:** 100% Polyester  
**widh fabric:** 140 cm

**fireproof norm:** BS 5852:2006 Part 1 - Cigarette test - PASS;  
EN 1021-1 Cigarette test - PASS  
**martindale:** > 50.000 cycles



# alma

# cat.W



W099



W085



W0159



W0118



W0116



W0083



W0250



W0171



W0117



W0251



W0235



W0122

**composition:** 65% PU | 35% CO  
**widh fabric:** 140 cm  
**fireproof norm:** EN 1021-1:2015 | EN 1021-2:2015 | IMO MSC. 307 (88) A.1 P.8  
**martindale:** >100.000 cycles



# one

# cat.A



A6290



A6291



A6335



A6697

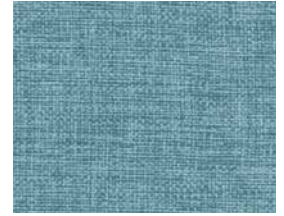

A6698



A6699



A6677



A6700

**composition:** 100% Poliolefin  
**widh fabric:** 140 cm

**fireproof norm:** Fire proof norm UNE EN1021-1:2006; BS 5852:2006 (cigarette)  
**martindale:** > 40.000 cycles



# two

# cat.A



A0468



A06273



A6287



A6334



A6293

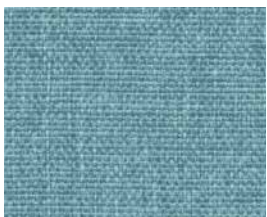

A6286



A6297



A6321

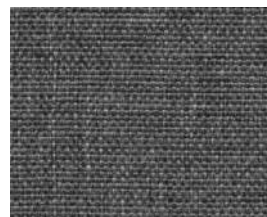

A6275



A6292



A0413



A6701

**composition:** 100% Poliolefin  
**widh fabric:** 140 cm  
**fireproof norm:** UNE EN1021-1:2006; BS 5852:2006 (cigarette)  
**martindale:** > 40.000 cycles



# four

# cat.A



A6663



A6252

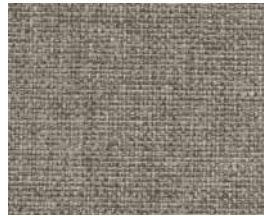

A6251

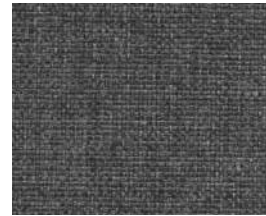

A6664



A6696



A6249



A6224



A6221

**composition:** 100% Poliolefin  
**widh fabric:** 140 cm

**fireproof norm:** Fire proof norm UNE EN1021-1:2006; BS 5852:2006 (cigarette)  
**martindale:** > 40.000 cycles



# picasso

# cat.A



A6681



A6326

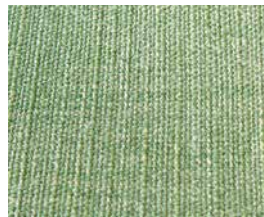

A6683



A6282



A6332



A6281



A6329



A6330



A6682

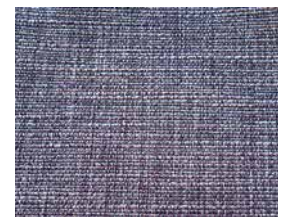

A6331



A6328



A6684

**composition:** 59% Polyester | 41% Acetate  
**widh fabric:** 140 cm  
**fireproof norm:** BS 5852:2006 Part 1 - Cigarette test - PASS; EN 1021-1 Cigarette test - PASS  
**martindale:** >35.000 cycles





A6307



A6641



A6642



A6311



A6309



A6333



A6678



A6313



A6305



A6643



A6295



A6312



A6644



A6645



A6679



A6646



A6298



A6263



A6310



A6294



A6302



A6299



A6680

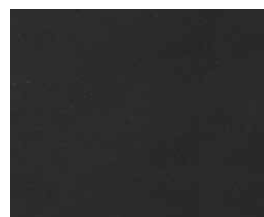

A6308

**composition:** 100% Polyester  
**widh fabric:** 140 cm



**fireproof norm:** BS 5852:2006 Part 1 - Cigarette test - PASS; EN 1021-1 Cigarette test - PASS

**martindale:** >100.000 cycles

# angel combo

cat.B



B9309



B9310



B9311

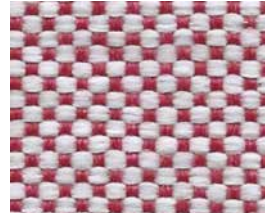

B9312

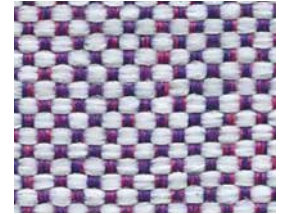

B9313



B9314



B9315

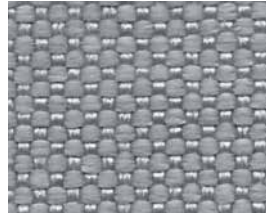

B9209



B9208



B9316



B9317



B9318



B9207



B9319



B9320



B9281



B9321



B9322



B9291



B9323

**composition:** 100% PP FR  
**width fabric:** 140 cm



**fireproof norm:** ITALY: UNI 9175 Class 1IM | EUROPA: EN 1021 1-2 | ENGLAND: BS 5852 IS CRIB 5 | FRANCE: NF D 60-013 (art. AM 18) | U.S.A.: California TB 117:2013  
NAUTICAL: FTP Code 307(88):10 Annex 1 Part 8  
**martindale:** ≥ 50.000 cycles

# angel trick

cat.B



B9324



B9325

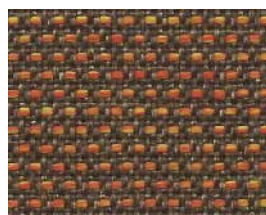

B9290



B9326



B9327



B9328

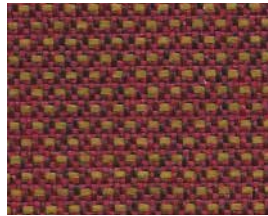

B9329

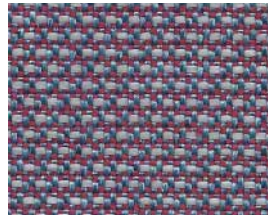

B9206



B9330

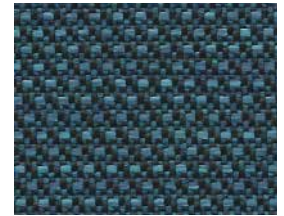

B9331



B9205

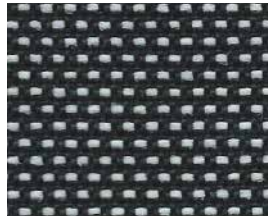

B9332

**composition:** 100% PP FR

**widh fabric:** 140 cm

**fireproof norm:** ITALY: UNI 9175 Class 1IM | EUROPA: EN 1021 1-2 | ENGLAND: BS 5852 IS CRIB 5 | FRANCE: NF D 60-013 (art. AM 18) | U.S.A.: California TB 117:2013 NAUTICAL: FTP Code 307(88):10 Annex 1 Part 8

**martindale:** ≥ 40.000 cycles



## valencia

## cat.B

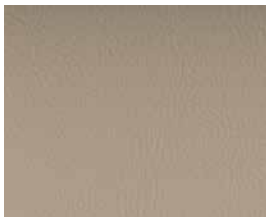

B0031



B1718



B0322



B1023

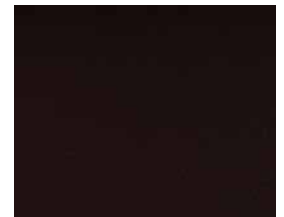

B2560

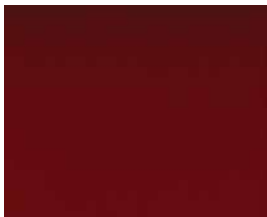

B2542



B0069



B0917



B2564



B2558

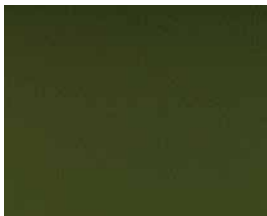

B3416

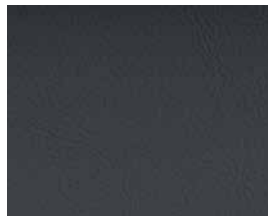

B0887



B9308

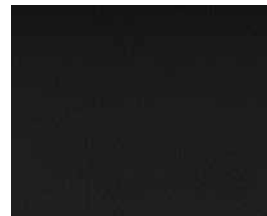

B1900



B0977



B0001

**composition:** Vinyl / Urethane Topcoat

**widh fabric:** 137 cm

**fireproof norm:** EN 1021 Part 1 & 2 | ES: UNE 23.727-90 1R/M.2 | FR: NF P 92-503/M2 | DE: DIN 4102 B2 | IT: UNI 9175 (1987) / UNI 9175/FA1 (1994) Classe 1.IM (UNO I EMME) | AT: ÖNORM B 3825, Gruppe 1 - Schwerbrennbares Verhalten | AT: ÖNORM A 3800 Teil 1, Qualmbildungsklasse Q1 - schwachqualmend | IMO FTP 2010 Code MSC.307 (88) Part 8 3.1 & 3.2 | US: FMVSS 302 | US: FAR 25/853 (MED) Marine Equipment Directive (in its current valid version) | ECE R118 (replaces Directive 95/28/CE) | EN 71-2:2006+A1:2007 - Safety of Toys - Parte 2: Flammability

**martindale:** >300.000 cycles



# dynactiv™ 160

cat.B

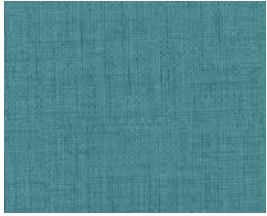

B9354

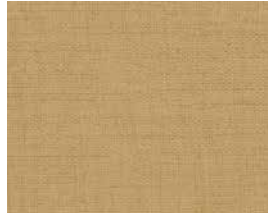

B9355

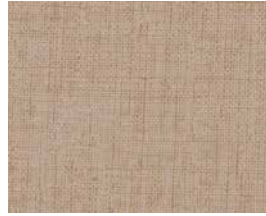

B9356

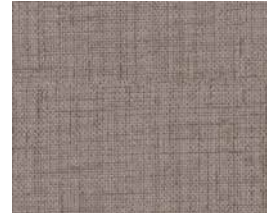

B9357

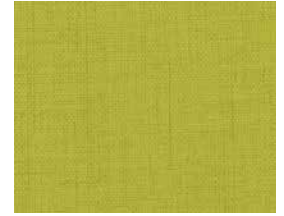

B9358

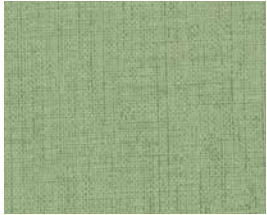

B9359

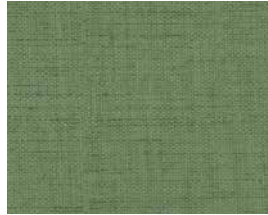

B9360



B9361



B9362



B9363



B9364

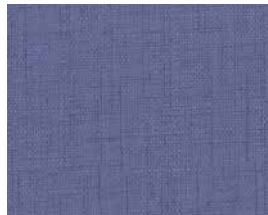

B9365



B9366



B9367



B9368



B9369



B9370

**composition:** 89% PVC | 11% CO  
**width fabric:** 140 cm

**fireproof norm:** EN 1021 (1-2) | M2 | B2 | BS55852 (CRIB 5) | IMO A652  
**martindale:** 150.000 cycles



# aurora

cat.B

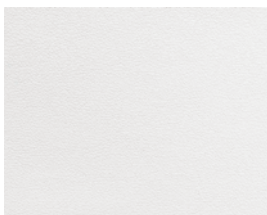

B9334



B1021



B9278



B9277



B9333



B9335



B9336



B9337

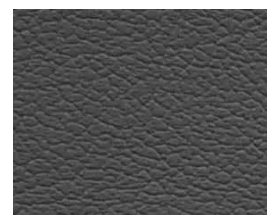

B9338

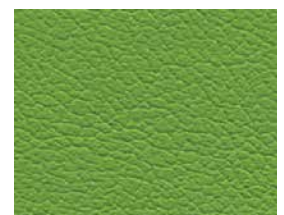

B9339



B9340



B9341



B9342



B0783



B9343



B9344



B9345



B9346



B9301



B9347

**composition:** 35% PU | 65% PES  
**width fabric:** 140 cm



**fireproof norm:** UNE EN 1021-1/2 | BS 5852 CRIB 5 | M2 (UNE 23723-901R) | B2 (DIN 4102-1) | IMO MSC.307 (88) A.1 P.8 | CAL.TB 117-2000 S.1  
**martindale:** >100.000 cycles

## abaka

## cat.B

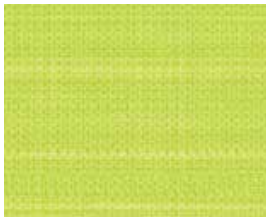

B9193



B9371



B9264

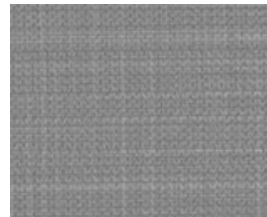

B9372



B9263



B9373



B9265

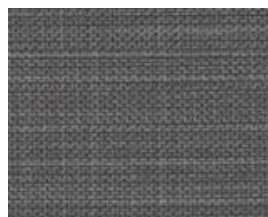

B9266



B9374



B9375



B9376

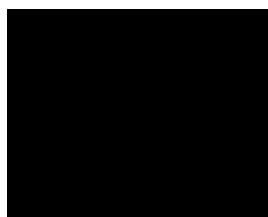

B9377

**composition:** 88% PVC | 12% PES/CO  
**width fabric:** 140 cm



**fireproof norm:** UNE EN 1021-1/2 | BS 5852 CRIB 5 | M2 (NFP92503) | B2 (DIN 4102-1) | IMO A652 (16)  
**martindale:** >80.000 cycles



# dynactiv™ 275

cat.B



B9378



B0862



B9379



B9380



B0994



B9381



B9382



B9383

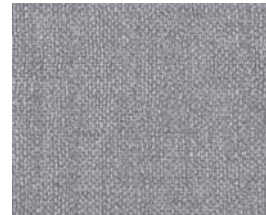

B9384



B9385



B0963



B0955



B9386

**composition:** 78% PVC | 19% PES | 3% PU  
**widh fabric:** 140 cm  
**fireproof norm:** UNE EN 1021 1-2 | M2 (UNE 23723-90)  
**martindale:** 150.000 cycles



# esprit dream cosy

cat.Y



Y0302



Y0553

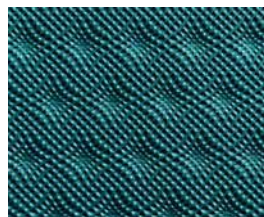

Y0436

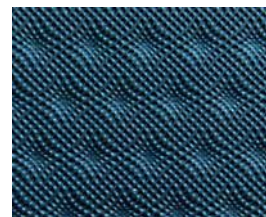

Y0311



Y0554



Y0555



Y0556



Y0557

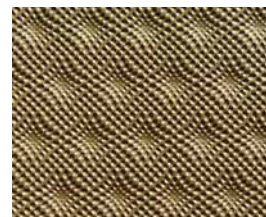

Y0430



Y0431

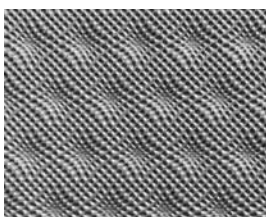

Y0432



Y0429

**composition:** 83% PVC | 14% PES/CO | 3% PU  
**widh fabric:** 140 cm  
**fireproof norm:** M2 (NF P 92503) | B2 (DIN 4102) | NF EN 1021-1 | NF EN 1021-2 |  
 BS 5852 CRIB 5 | IMO FTP Code P.8 | Cal.TB 117/133  
**martindale:** 150.000 cycles





Y0504



Y0505



Y0506



Y0507



Y0454



Y0508

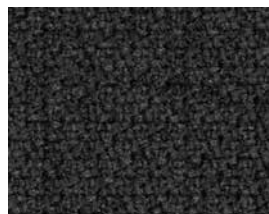

Y0509



Y0510



Y0455



Y0511



Y0512



Y0513



Y0514



Y0515



Y0516



Y0517



Y0518



Y0519



Y0520



Y0521



Y0522

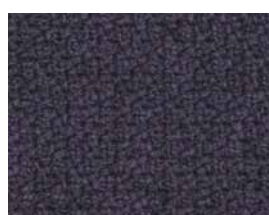

Y0523



Y0524



Y0525



Y0456

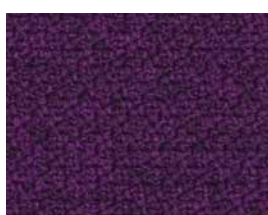

Y0526



Y0527

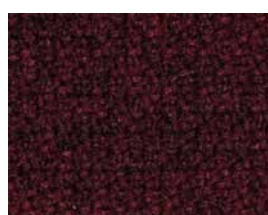

Y0528



Y0529

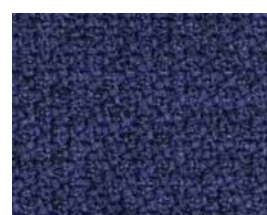

Y0530

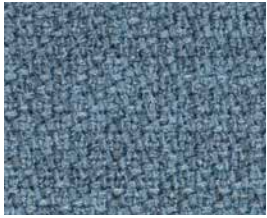

Y0531

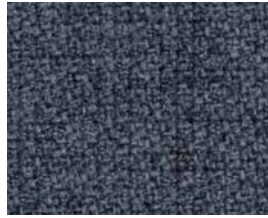

Y0457

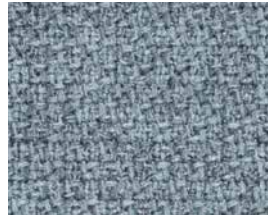

Y0458

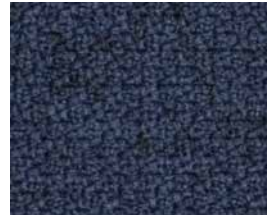

Y0532



Y0533

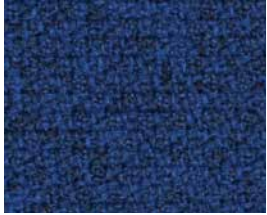

Y0534



Y0535

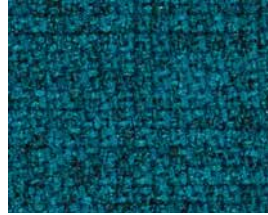

Y0536



Y0537



Y0538



Y0539



Y0540

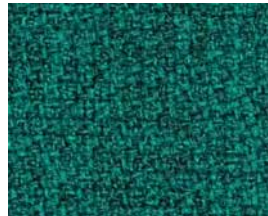

Y0541



Y0542



Y0543



Y0544



Y0545



Y0546



Y0547



Y0548



Y0549



Y0550

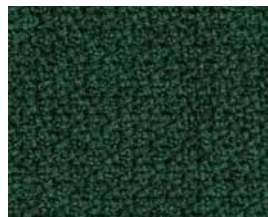

Y0551



Y0552

**composition:** 100% Trevira cs  
**width fabric:** 140 cm



**fireproof norm:** IMO msc 307 (88) Annex I part 8 Red Certificate IMO | BS EN 1021 1&2 Cigarette and Match | BS EN 1021-1 cigarette  
BS 5852 Part 1 0,1 Cigarette & match | BS 5852 Crib 5 | BS 7176 Medium hazard  
DIN 4102 B1 | NFP 92-503/504/505 M1 | ÖNORM B 3825-B1-3800-Q1 UK  
Class Uno UNI 9175 Class 1 | EMME | FAR/JAR 25.853 (a) (i) (ii) | CA TB 117-2013  
DIN EN 13501-1 B-s1,d0  
**martindale:** 100.000 cycles

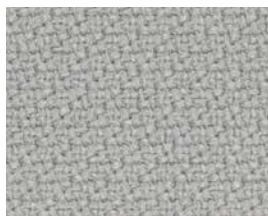

Y0461

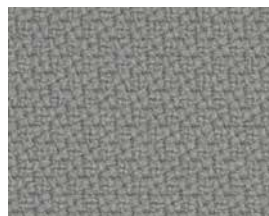

Y0438



Y0451

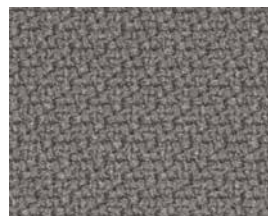

Y0462



Y0441

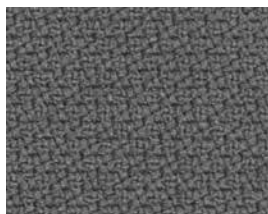

Y0463



Y0439

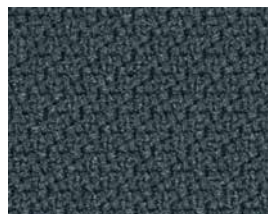

Y0445

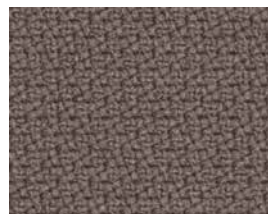

Y0464

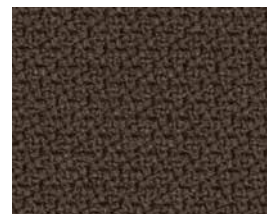

Y0503

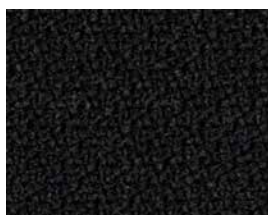

Y0465



Y0466



Y0467



Y0468

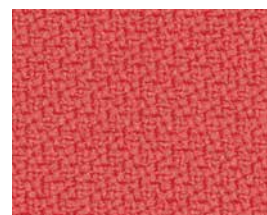

Y0469



Y0470



Y0452



Y0471



Y0472

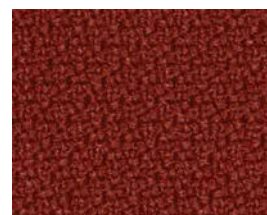

Y0473



Y0474



Y0475



Y0476



Y0477



Y0442



Y0478



Y0479



Y0480



Y0481

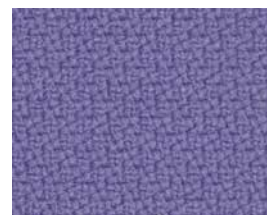

Y0482

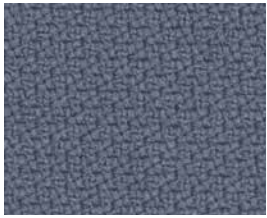

Y0483

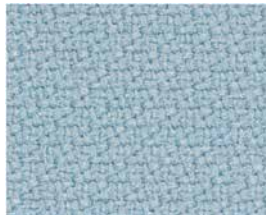

Y0484

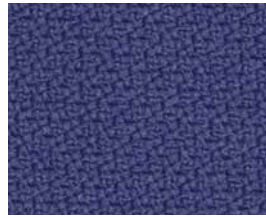

Y0485

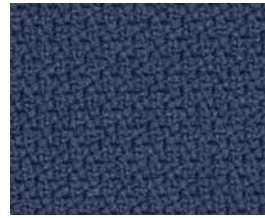

Y0486

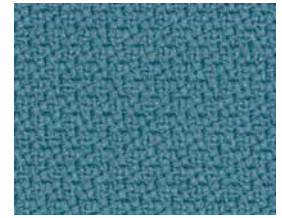

Y0487

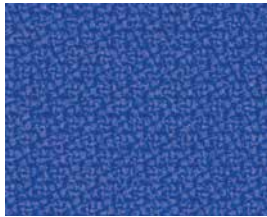

Y0488

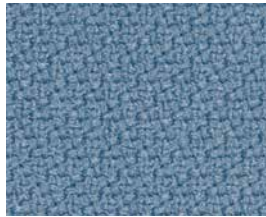

Y0444

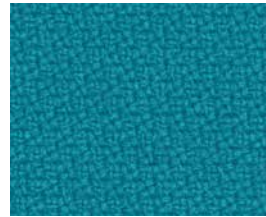

Y0489

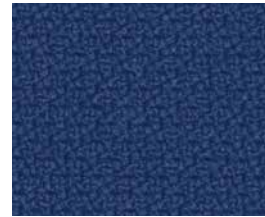

Y0490

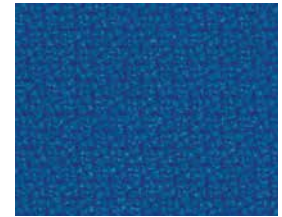

Y0491



Y0453



Y0443



Y0492



Y0493

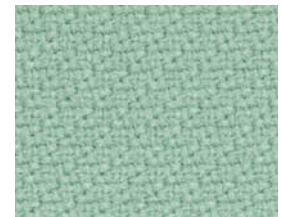

Y0494



Y0495



Y0496



Y0497



Y0448

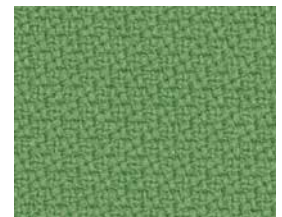

Y0498



Y0499



Y0446

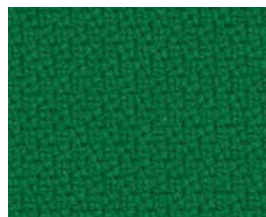

Y0500



Y0501



Y0449



Y0447



Y0502

**composition:** 100% Trevira cs  
**width fabric:** 140 cm



**fireproof norm:** IMO msc 307 (88) Annex I part 8 Red Certificate IMO | BS EN 1021 1&2 Cigarette and Match | BS EN 1021-1 cigarette  
BS 5852 Part 1 0,1 Cigarette & match | BS 5852 Crib 5 | BS 7176 Medium hazard  
DIN 4102 B1 | NFP 92-503/504/505 M1 | ÖNORM B 3825-B1-3800-Q1 UK  
Class Uno UNI 9175 Class 1 | EMME | FAR/JAR 25.853 (a) (i) (ii) | CA TB 117-2013  
DIN EN 13501-1 B-s1,d0  
**martindale:** 100.000 cycles

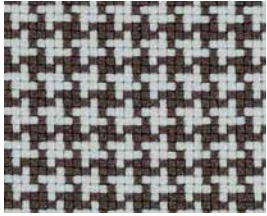

C9216

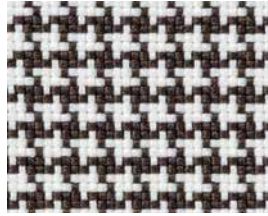

C9217

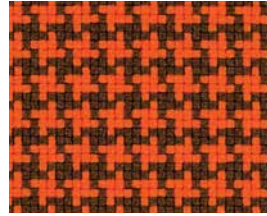

C9218

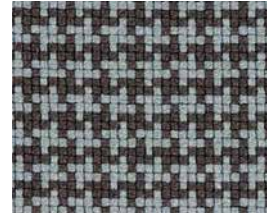

C9219

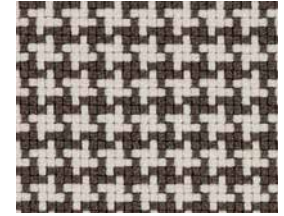

C9220

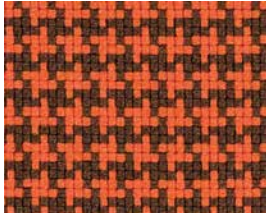

C9221

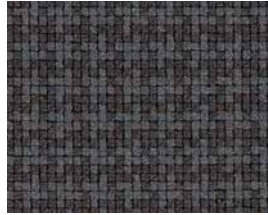

C9222



C9223

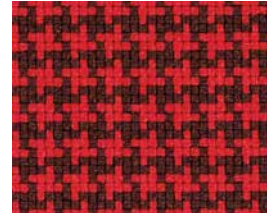

C9224

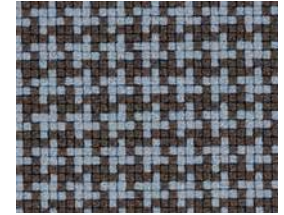

C9225



C9226



C9227

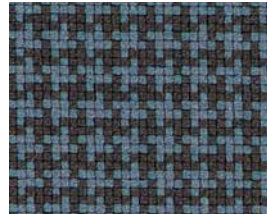

C9228



C9229



C9230



C9231

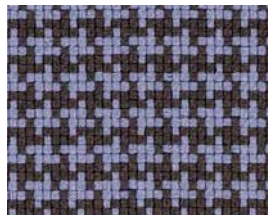

C9232



C9233

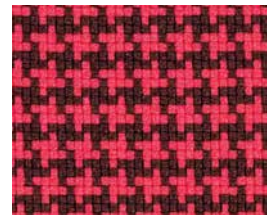

C9234



C9235



C9236



C9237

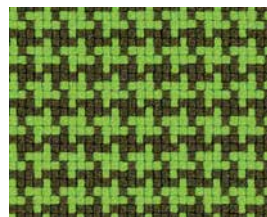

C9238



C9239



C9240

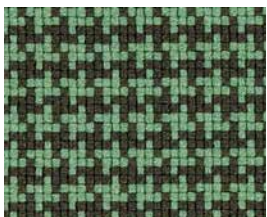

C9241



C9242

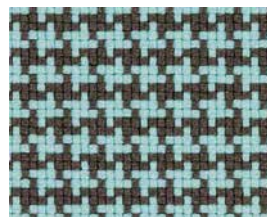

C9142

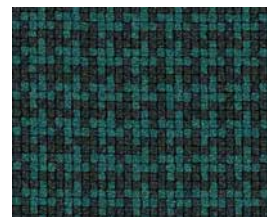

C9243



C9244

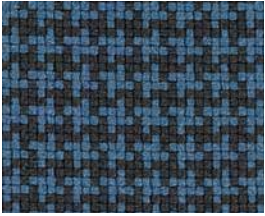

C9245



C9246

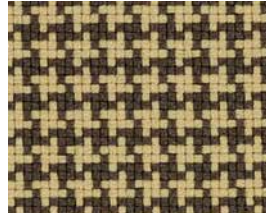

C9247

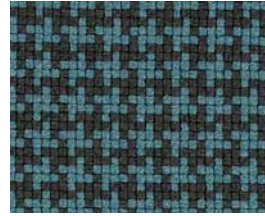

C9248

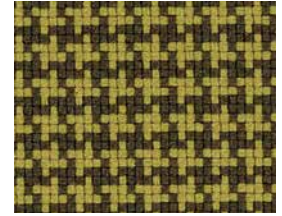

C9249



C9250

**composition:** 100% Trevira cs  
**width fabric:** 140 cm



**fireproof norm:** BS EN 1021 1&2 Cigarette and Match | BS EN 1021-1 cigarette  
BS 5852 Part 1 0,1 Cigarette & match | BS 7176 Medium hazard | BS 5852 Crib 5  
DIN 4102 B1 | NFP 92-503/504/505 M1 | Class Uno UNI 9175 Class 1 | EMME  
ÖNORM B 3825-B1-3800-Q1 UK | FAR/JAR 25.853 (a) (i) (ii) | CA TB 117-2013  
DIN EN 13501-1 B-s1,d0  
**martindale:** 80.000 cycles

go check

cat.C



C9145



C9251



C9182



C9252



C9177



C9253



C9254



C9255



C9181



C9256



C9257



C9258



C9144



C9259



C9260

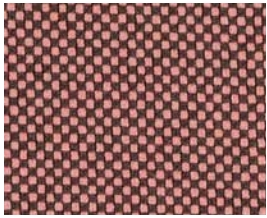

C9143

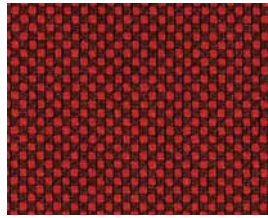

C9261

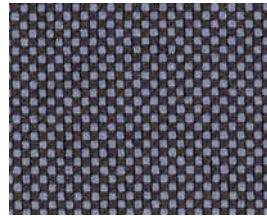

C9175

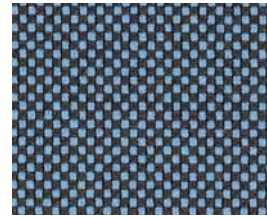

C9178

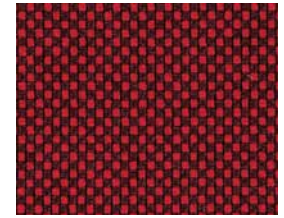

C9190



C9262

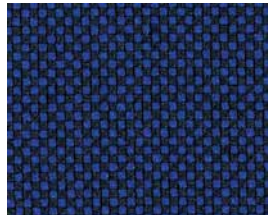

C9263

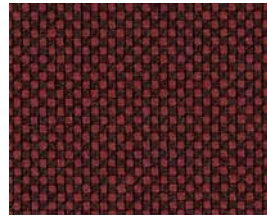

C9264



C9265

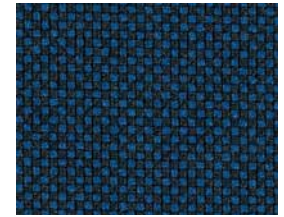

C9266



C9267



C9174



C9268



C9140



C9269



C9270



C9176



C9180



C9271



C9272



C9141



C9183



C9273



C9274



C9275

**composition:** 100% Trevira cs  
**width fabric:** 140 cm



**fireproof norm:** BS EN 1021 1&2 Cigarette and Match | BS EN 1021-1 cigarette  
BS 5852 Part 1 0,1 Cigarette & match | BS 5852 Crib 5 | BS 7176 Medium hazard  
DIN 4102 B1 | NFP 92-503/504/505 M1 | ÖNORM B 3825-B1-3800-Q1 UK  
Class Uno UNI 9175 Class 1 | EMME | FAR/JAR 25.853 (a) (i) (ii) | CA TB 117-2013  
DIN EN 13501-1 B-s1,d0  
**martindale:** 80.000 cycles



# trendy

# cat.C



C9191



C9186



C9185



C9187



C9188



C9179



C9196



C9199



C9203



C9194

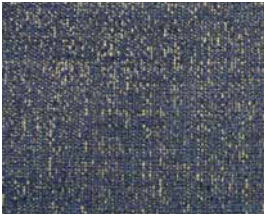

C9197



C9200



C9205



C9195



C9198



C9201

**composition:** 58% AC | 35% textured PL | 4% PL | 3% VI

**widh fabric:** 140 cm

**martindale:** >100.000 cycles

**fireproof norm:**



# halfie

# cat.D



D2766



D2767

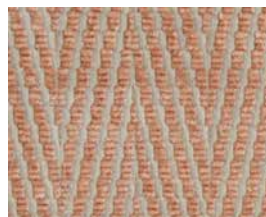

D2768



D2749



D2769



D2770



D2771



D2750



D2772

**composition:** 44% VI | 30% CO | 26% PL  
**widh fabric:** 140 cm

**martindale:** 50.000 cycles  
**fireproof norm:**



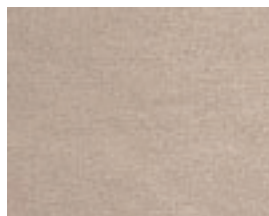

D2774



D2762



D2775



D2776



D2777



D2778



D2751



D2761



D2779



D2780



D2781



D2755



D2782



D2783



D2753

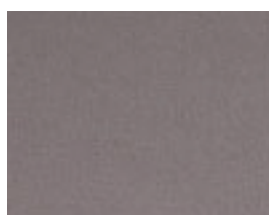

D2752

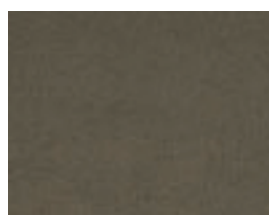

D2765

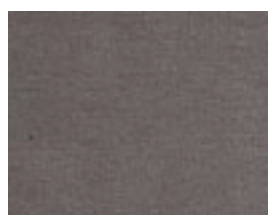

D2754



D2784



D2785



D2786



D2787



D2788



D2789

**composition:** 100% P, FR treated  
**width fabric:** 140 cm

**fireproof norm:** BS 7176 Medium Hazard, crib 5, BS 5867, BS 7175, IMO, CAL 117 and NFPA 260  
**martindale:** >100.000 cycles





P2000



P2004

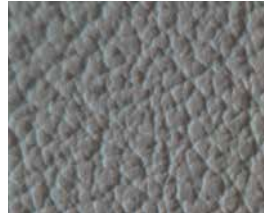

P2008



P2012



P2016



P2001



P2005



P2009

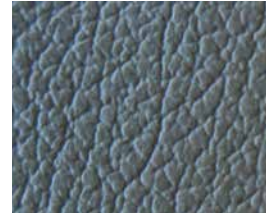

P2013



P2017

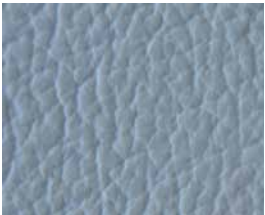

P2002

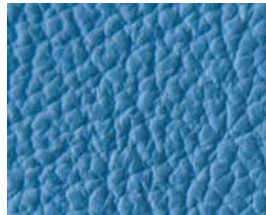

P2006

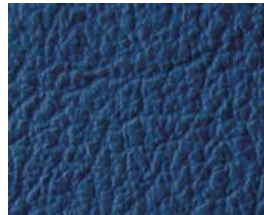

P2010



P2014



P2018

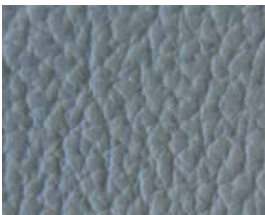

P2003

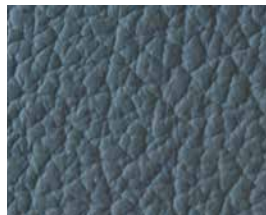

P2007



P2011



P2015



P2019

**composition:** Bovine origin

**fireproof norm:** BS 5852:1979 - BS EN 1021-1-2:2006





P2020



P2026



P2032



P2039



P2045



P2021



P2027



P2033



P2040



P2046



P2022



P2028



P2034

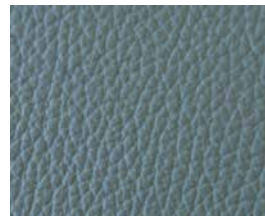

P2041



P2047



P2023



P2029

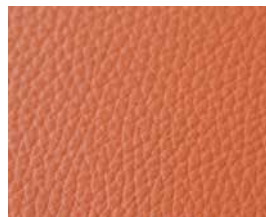

P2035



P2042



P2048



P2024



P2030

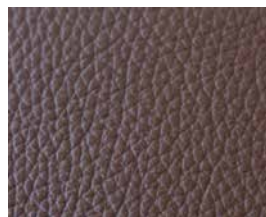

P2037

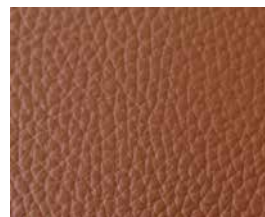

P2043

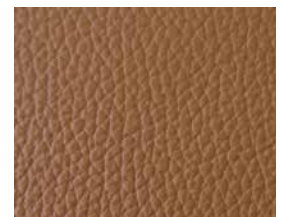

P2049



P2025



P2031



P2038

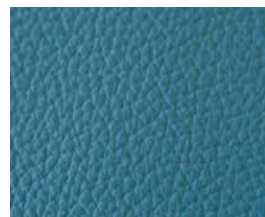

P2044

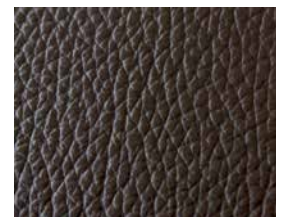

P2050

**composition:** Bovine origin  
**fireproof norm:** BS 5852:1979 - BS EN 1021-1-2:2006



## OPTIONS

Opções | Options | Optionen | Opciones | 选项

### UPHOLSTERED BACKS

Estofos - Costas | Tapisserie - Dossier | Rückenpolsterung | Tapiceria - Respaldo | 软包装饰-椅背



**B3**  
ZM0035



**B6**  
ZM0036



**Q12**  
ZM0037



**LIN 3**  
ZM0038



**CAPI B**  
ZM0071



**CAPI 01**  
ZM0039

### CUSTOM-MADE SEATING

Assentos | Assises | Sitze | Asientos | 座位定制

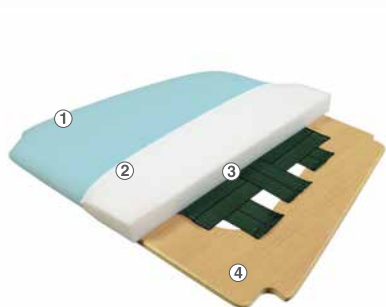

COD. **Comfort Plus | EC04**

- ① Fabric/Tecido/Tissu/Stoff/Tela/面料
- ② Foam/Espuma/Mousse/Schaumstoff/Espuma/海绵  
35/39kgHR-40mm (77.18/86lb-1.6") [E0003A]
- ③ Webbing/Percinta/Sangles/Gurte/Cinchas/绑带  
[00011]
- ④ Plywood/Contraplacado/Contreplaqué/Sperrholz/  
Contrachapado/胶合板 15 mm (0.6") [CDF15]

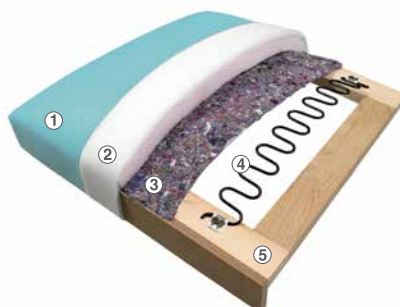

COD. **Ultra Comfort | EC05**

- ① Fabric/Tecido/Tissu/Stoff/Tela/面料
- ② Foam/Espuma/Mousse/Schaumstoff/Espuma/海绵  
35/39kgHR-40mm (77.18/86lb-1.6") [E0003A]
- ③ Acrylic Wast Needle Loom Felt/Feltro Agulhado/Feutre  
Aiguilleté/3 Nadelfilz/Fielro Punzonado/晴纶针织
- ④ Nozag Springs/Muelles Zig-Zag/Ressorts No-Sag/  
Zick-zack-Feder/Molas Ziguezague/S型弹簧 [ZM0049]
- ⑤ Solid Wood Frame/Grade Madeira/Cadre en Bois/  
Holzrahmen/Bastidor de Madera/木框架  
22 mm (0.9") [GC000]



COD. **Super Comfort | EC06**

- ① Fabric/Tecido/Tissu/Stoff/Tela/面料
- ② Foam/Espuma/Mousse/Schaumstoff/Espuma/海绵  
35/39kgHR-40mm (77.18/86lb-1.6") [E0003A]
- ③ Acrylic Wast Needle Loom Felt/Feltro Agulhado/ Feutre  
Aiguilleté/Nadelfilz/Fielro Punzonado/晴纶针织
- ④ Pocket Springs/Molas/Ressorts/Feder/Muelles/弹簧  
[00296]
- ⑤ Plywood/Contraplacado/Contreplaqué/Sperrholz/  
Contrachapado/胶合板 15 mm (0.6") [ZM0164]

### UPHOLSTERY DETAILS

Detalhes de Estofa | DétailsTapisserie | Polsterungsdetails | Detalle de Tapizado | 软包细节

Piping | Vivos | Passe Poile | Keder | Vivos | 单边



**ZM007**

SimplePiping | Vivo Simples | Passe Poile | Simple |  
Keder | Vivo Simples | 单边



**ZM006**

DoublePiping | Vivo Duplo | Passe Poile Double  
Doppelkeder | Vivo Doble | 双边

## STAINLESS STEEL KICKPLATE

Proteção Aço Inox | Protection Inox | Metalsteg für Barhocker  
 Protección Inox | 不锈钢踏板



COD. TP001

- i** - Available for all barstools.
- Disponível para todos os bancos bar.
- Disponible pour tous les tabourets bar.
- Für alle Barhocker erhältlich
- Disponible para todos los taburetes bar.
- 适用于所有吧椅

## STACKABLE

Empilhável | Empilable | Stapelbar | Apilable | 层叠



COD.EMP01

- i** - Available for other models, upon request.
- Disponível para outros modelos, sob consulta.
- Disponible pour d'autres modèles, nous consulter.
- Nach Anfrage, auch für andere Modelle verfügbar
- Disponible para otros modelos, bajo consulta.
- 可用于其他系列的椅子

## GLIDES

Deslizadores | Patins | Gleiter | Tacos | 防滑贴



COD. DES01

White Plastic & Felt  
 Plástico Branco & feltro  
 Plastique Blanc & Feutre  
 Nylon weiß & Filz  
 Plástico Blanco & Fieltro  
 白色塑料&毛毡



COD. DES02

Brown Plastic & Felt  
 Plástico Castanho & Feltro  
 Brown Plastic & Felt  
 Plástico Castanho & Feltro  
 Plastique Marron & Feutre  
 Nylon braun & Filz  
 Plástico Marón & Fieltro  
 棕色塑料&毛毡



COD. DES03

Plastic & Metal  
 Plástico & Metal  
 Plastique & Metal  
 Nylon & Metal Plástico & Metal  
 塑料&金属



COD. DES04

White Plastic  
 Plástico Branco  
 Plastique Blanc  
 Nylon weiß  
 Plástico Blanco  
 白色塑料



COD. DES05

Brown Plastic  
 Plástico Castanho  
 Plastique Marron  
 Nylon braun  
 Plástico Marón  
 棕色塑料

COD. DES01; COD. DES02

Wood - Parquet Flooring / Pavimento Madeira -  
 Parket / Sol Bois - Parquet Flottant / Holz- und  
 Parkettboden / Piso Madera - Parquet  
 实木 - 拼花地板

COD. DES03

Carpet Flooring / Pavimento Carpete /  
 Sol Moquette / Tapis / Teppichboden /  
 Piso Alfombra / 地毯

COD. DES04; COD. DES05

Tiles Flooring / Pavimento Cerâmica  
 Sol Céramique / Fließboden / Piso Ceramica  
 瓷砖地面

## VERY IMPORTANT ADVICE

Conselho muito importante | conseil très important | wichtige hinweise | consejo muy importante | 非常重要的建议



International Plant  
 Protection Convention

- i** For small quantities, we recommend always the use of pallets;  
 Para pequenas quantidades, nós recomendamos sempre o uso de paletes;  
 Pour de petites quantités nous conseillons toujours la palettisation;  
 Für Kleinmengen, empfehlen wir stets Lieferung in Paletten;  
 Para pequeñas cantidades recomendamos siempre el uso de palets de madera;  
 非常重要的建议 数量少的订单, 我们建议使用托盘包装。

# SPECIAL CARE AND MAINTENANCE

Conselhos Especiais | Conseils Spécifiques | Besondere Hinweise | Consejos Especiales | 特别的建议



EN

- 1) Given the continuous development of our products, we reserve the right to alter a product in terms of its design, materials, and construction, or in the production technology used. Our effort is to improve the value and the design of the product. The dimensions shown in the catalogue are for guidance and may differ for particular cases.
- 2) Our furniture is designed to be used indoors under standard conditions with a relative humidity between 25 and 60% and a temperature between 18 and 24° C. Otherwise this will have negative effects on the furniture and can result in distortions in the form of wood and upholstery.
- 3) The warranty does not cover defects or wear and tear caused by the normal use of the product or damage caused by accidents or mishandling during installation. Another use, like putting inappropriate objects, climbing, kneeling, jumping, dropping, hitting with the furniture or placing it in the outside, may result in damage to the furniture, with potential injuries to the user.
- 4) Please specify the wood finish according to our colour samples displayed in our brochure and website. However, these should be considered as a general guide, so do not expect a replica. Different woods and veneers can absorb finish differently, and thus cause variations of shades and textures. With regard to the natural colour, the colour samples are for guidance only. The finish of the veneer is slightly different from hardwood since this is not the same material.
- 5) Changes in texture, minor deviations in colour and natural growth defects are not considered failures, they only prove the genuine nature of wood. As a natural element, the wood is always reacting to the surrounding environment. This may result in small cracks in the paint or in a slight penetration of the wooden structure on the surface during the lifetime of the product. This should not be considered as a defect but natural material.
- 6) The warranty does not cover quality defects on fabric, faux leather or real leather used in upholstered products and the non-use of metal kickplates on barstools. Regarding upholstery with customer's own material (COM), we reserve the right not to accept material that we consider inappropriate to upholster our products. Before sending us the material, please make sure you clearly mark FACE SIDE on the fabric. We reserve the right to choose the Face Side in the case it is unmarked. In the case of barstools in particular, we recommend the use of materials with greater resistance to abrasion.
- 7) Fabrics, leather and / or faux leather may get stained when in contact with other darker materials such as dyed fabric, denim, newspapers, magazines, etc. This chemical colour pigmentation reaction is not a sign of poor quality of our products and is therefore not covered by our warranty.
- 8) The characteristics of some upholstery materials or the technology used in the upholstery process can cause some damages to the upholstered products, namely the appearance of slight ripples and wrinkles on upholstered products during the upholstery process or during the use of the product. This should not be subject to any complaint. When upholstering round shapes, wrinkling of the fabric is technically unavoidable.
- 9) Regarding the models to be upholstered with real leather or with velvet supplied by the client, the upholstery material should be delivered in rolls. Avoid bending the leather or the velvet, as this can cause its deformation. In case this happens, we reserve the right to refuse the material. The leather is a natural product and it is for this reason that there must be a degree of acceptance in respect of inequalities on the surface and structure, as well as small defects such as scars, scratches, etc. arising out of the natural life of the animal. These defects represent and only prove the authenticity of the leather.
- 10) A double piping should be applied whenever the products are upholstered with leather or faux leather.
- 11) Do not expose the furniture to water, excessive heat and direct sunlight. As a result of the direct exposure to sunlight, the color of wood, fabric or plastic may change.
- 12) We do not recommend the use of furniture on uneven pavement, as this may damage the furniture.
- 13) The use of plastic, nylon or nylon & metal glides can damage the wood flooring or parquet.
- 14) We recommend checking the condition of the glides periodically to avoid damage to the floor or to the product.
- 15) Sharp objects, keys, cutlery, lady bags, hard seams, zippers, pet claws, etc., can damage the wood, veneer and fabric.
- 16) All screws should be tightened periodically, in order to ensure the durability and strength of the product. The looseness in the joints can cause excessive stress on the components and therefore cause damage to the product.
- 17) The seat height and overall height of the product may differ from standard dimensions depending on the chosen upholstery option.
- 18) The stackable version may differ from the non-stackable one in respect of stretchers, seat type, shape of the legs and arms.

**Fenabel -The heart of seating warranty, does NOT COVER the failure to comply with these recommendations.**

**PT**

- 1) Considerando o nosso desenvolvimento contínuo, reservamos o direito de alterar um produto no que diz respeito ao seu design, materiais utilizados, construção e tecnologia de produção. O nosso esforço é melhorar o valor e design do produto. As dimensões apresentadas no catálogo são para orientação podendo diferir para casos particulares.
- 2) O mobiliário é desenhado para ser usado no interior em condições standard, com uma humidade relativa entre 25 e 60% e uma temperatura entre 18 e 24°C. Caso contrário terá efeitos negativos no mobiliário e pode resultar em distorções na forma da madeira e do estofado.
- 3) A garantia não contempla defeitos ou desgaste causados pelo uso normal do produto nem estragos ou acidentes causados pelo mau manuseamento durante a instalação. Outro uso, como colocar objectos inapropriados, subir, ajoelhar-se, saltar, deixar cair, bater ou colocar no exterior, pode resultar em estragos no mobiliário, com potenciais danos para quem o usa.
- 4) Por favor, especifique o acabamento de acordo com as nossas amostras de cor apresentadas no nosso catálogo e website. Todavia, estas devem ser consideradas como um guia geral, por isso não espere uma réplica. Diferentes madeiras e folheados podem absorver o acabamento de diferente maneira e por tal motivo causar variações de tonalidades e texturas. No que respeita à cor natural, as amostras de cor são apenas para orientação. O acabamento do folheado é ligeiramente diferente da madeira maciça uma vez que este não é material igual.
- 5) Mudanças na textura, desvios menores na cor e defeitos naturais de crescimento não são considerados como falhas; pelo contrário, comprovam a natureza genuína da madeira. Sendo um material natural, a madeira reage permanentemente ao ambiente envolvente. Esta reação pode consistir em pequenas fendas na pintura ou numa ligeira penetração desta na estrutura da madeira durante o ciclo de vida do produto. Isto não deve ser considerado um defeito de fabrico, mas uma consequência da condição natural da madeira.
- 6) A garantia não cobre defeitos de qualidade do tecido, pele ou imitação de pele utilizado no estofado dos produtos e o não uso das proteções de metal nos bancos de bar. No que diz respeito ao estofado em tecido de cliente, reservamos o direito de não aceitar material que consideramos inadequado para estofar os nossos produtos. Quando enviar tecido, a prioridade é marcar o lado que quer utilizar para estofado. Reservamos o direito de escolher o lado no caso deste não estar marcado. No caso dos bancos de bar em particular, recomendamos o uso preferencialmente de materiais com maior resistência a abrasão.
- 7) Tecidos, pele e/ou imitação de pele claros podem ficar manchados quando em contacto com outros materiais mais escuros tais como: tecidos tingidos, gangas, jornais, revistas, etc. Esta reação química de pigmentação de cor não é um sinal de baixa qualidade e por isso não é coberta pela garantia.
- 8) As características de algum material para estofado ou da tecnologia utilizada no processo podem causar alguns pequenos defeitos no produto tais como pequenas rugas ou pregas no estofado durante o processo de produção ou como consequência do uso do produto. Este facto não deve ser objecto de qualquer reclamação. Quando se estofa formas redondas o enrugamento do tecido é tecnicamente inevitável.
- 9) Para estofar os modelos com pele natural ou com veludo fornecido pelo cliente, o material deverá ser entregue em rolos. Evitar dobrar a pele ou o veludo pois pode causar a sua deformação. No caso de isto acontecer, reservamos o direito de recusar o material. A pele é um produto natural e é por essa razão que deve existir um certo grau de aceitação no que diz respeito a desigualdades na superfície e estrutura, bem como pequenos defeitos tais como cicatrizes, arranhões, etc. que advêm da vida natural do animal. Estes defeitos representam e provam a "autenticidade da pele".
- 10) Sempre que o estofado for em pele ou imitação de pele deverá ser aplicado vivo duplo.
- 11) Não expor o mobiliário à água, calor excessivo e luz solar directa. Como resultado da exposição directa aos raios solares, a cor da madeira, tecido ou plástico podem sofrer alterações.
- 12) Não é recomendável o uso de mobiliário em pavimento irregular, visto causar danos no mobiliário.
- 13) O uso de deslizadores de plástico, nylon ou nylon/metal pode danificar o pavimento em madeira ou parquet
- 14) Recomendamos a verificação do estado dos deslizadores periodicamente de forma a evitar o dano do pavimento ou do produto.
- 15) Objectos afiados, chaves, talheres, malas de senhora, costuras mais duras, fechos de calças, garras de animais, etc., podem causar danos na madeira, no folheado e no tecido.
- 16) Todos os parafusos devem ser apertados periodicamente, o que resultará numa maior durabilidade e resistência do produto. A folga nas uniões pode causar tensão excessiva sobre as peças e provocar danos no produto.
- 17) A altura do assento ou altura total do produto pode variar das dimensões standard dependendo da opção de estofado.
- 18) A versão empilhável pode diferir da versão não-empilhável no que respeita a travessas, tipo de assento, forma dos pés e braços.

**A garantia da Fenabel - The heart of seating, NÃO COBRE a não observância destas recomendações**





FR

- 1) Considérant notre développement constant, nous nous réservons le droit de modifier un produit en ce qui concerne son design, les matériaux utilisés, la construction et technologie de production. Notre effort est d'améliorer la valeur et le design du produit. Les dimensions présentées sur le catalogue sont indicatives pouvant différer dans certains cas particulier.
- 2) Le mobilier est dessiné pour être utilisé à l'intérieur dans des conditions standards avec une humidité relative entre 25% et 60% et une température entre 18°C et 24°C. Cas contraire il y aura des effets négatifs sur le mobilier et il peut résulter en distorsions sur la forme du bois et de la tapisserie.
- 3) La garantie ne couvre pas les défauts ou l'usure causés par un usage normal du produit ni endommagement ou accident causé par une mauvaise manipulation lors de l'installation. Toute autre utilisation, comme la pose d'objets inappropriés, monter, s'agenouiller, sauter, laisser tomber, frapper ou exposer à l'extérieur, peut endommager le matériel ainsi que la personne qui l'utilise.
- 4) Merci d'indiquer la finition du bois en fonction des échantillons de bois présentés dans notre catalogue ou website, cependant ceux-ci sont considérés comme un guide général. Par conséquent, ne vous attendez pas à une copie exacte. Différentes essences de bois ou placage peuvent absorber la finition de forme différente et pour cela la cause de variation de tonalité et texture. En ce qui concerne la finition naturel du bois, les échantillons de bois sont fournis à titre indicatif. La finition du placage est légèrement différente du bois massif, une fois que ce matériel n'est pas identique.
- 5) Des changements de texture, des variations minimales de couleur et des défauts naturels de croissance du bois, ne sont pas considérés comme des défauts, au contraire, ils prouvent la nature du bois. Comme élément naturel, le bois réagit toujours à l'environnement voisin. Cela peut aboutir à de petites fissures sur la peinture ou dans une légère pénétration de celle-ci dans le bois au cours de la durée de vie du produit. Cela ne devrait pas être considéré comme un défaut mais comme une conséquence naturelle du bois.
- 6) La garantie ne couvre pas les défauts de qualité de tissu, cuir, ou imitation de cuir utilisé sur la tapisserie des produits et la non utilisation des protections métal sur les tabourets bar. En ce qui concerne le mobilier avec tissu client, nous nous réservons le droit de refuser tout matériel qui n'est pas adapté à la tapisserie de nos sièges. Avant de nous expédier le matériel, assurez-vous que vous avez indiqué clairement le côté de la face du tissu à utiliser. Nous nous réservons le droit de déterminer la face à utiliser cas où celle-ci ne serait pas indiquée. Dans le cas des tabourets bar en particulier, nous vous conseillons de donner votre préférence à des matériaux de tapisserie résistant à l'abrasion.
- 7) Les tissus, cuir et/ou similicuir de couleur clair, peuvent être colorés lorsqu'en contact avec des couleurs foncées tels que : tissu teint, jeans, journaux, magazines, etc. pouvant de ce fait déteindre sur ceux-ci. Cette réaction chimique de pigmentation de couleur n'est pas un signe de mauvaise qualité et n'est donc pas couvert par la garantie.
- 8) Les caractéristiques de certains matériaux de rembourrage ou la technologie utilisée dans le processus de tapisserie peuvent causer des imperfections aux produits rembourrés: L'apparition de légères ondulations et des plis sur les produits rembourrés pendant le processus de rembourrage ou au cours de l'utilisation du produit. Lorsque l'on tapisse des formes rondes les plis des tissus sont techniquement inévitables.
- 9) Pour tapisser les modèles en cuir naturel ou un velour, fournis par le client, le matériel devra être livré en rouleaux. Dans tous les cas éviter de plier le cuir ou le velour, ce qui peut provoquer sa déformation, nous nous réservons le droit de refuser le matériel. Le cuir est un produit naturel, c'est pourquoi il est nécessaire d'accepter un certain degré d'irrégularités de la surface et de la structure, ainsi que des défauts mineurs tels que des cicatrices, égratignures, etc, marques qui viennent de la vie de l'animal. Ces défauts représentent et prouvent l'authenticité du cuir.
- 10) Lorsque les tapisseries sont en cuir ou similicuir il devra être appliqué un double passe poile.
- 11) Ne pas exposer les meubles à l'eau, à la chaleur excessive et à la lumière solaire directe. Comme réaction de l'exposition directe au soleil, la teinte du bois, des tissus et du plastique peuvent varier.
- 12) Il est déconseillé d'utiliser le mobilier sur des sol non régulier, pouvant endommager celui-ci.
- 13) L'utilisation de patins plastique, nylon ou nylon / métal peut endommager les sols en bois ou parquet.
- 14) Il est recommandé de vérifier l'état des patins périodiquement pour éviter d'endommager le sol ou le produit.
- 15) Les objets pointus comme par ex : des clés, des couverts, des sacs, des coutures plus épaisses, fermetures éclair de pantalon, des griffes d'animaux, etc., peuvent endommager le bois, placages et tissus.
- 16) Tous ce qui est vis et boulons doivent être resserrés périodiquement, permettant une meilleure durabilité et résistance du produit. Le jeu dans les articulations peut engendrer des contraintes excessives sur les composants et provoquer des dommages sur le produit.
- 17) La hauteur d'assise ou la hauteur totale du produit peut varier des dimensions standards selon le type de tapisserie.
- 18) La version empilable d'un modèle peut différer de la version non empilable, en ce qui concerne les traverses, le type d'assise, à la forme des pieds et des accoudoirs.

**La garantie Fenabel - The heart of seating, NE COUVRE PAS le non suivi de ces recommandations.**



DE

- 1) Im Rahmen unserer Verpflichtung zur ständigen Verbesserung unserer Produkte behalten wir uns das Recht zur Änderung des Designs, verwendeten Materialien und der Herstellungsweise vor. Die im Katalog angegebenen Maße sind Richtwerte und können im Einzelfall abweichen.
- 2) Die Möbel sind für Innenräume mit einer relativen Luftfeuchtigkeit zwischen 25% und 65% und einer Temperatur zwischen 18° und 24 ° C gedacht. Andernfalls kann es zu negativen Auswirkungen auf die Möbel haben und zu Verzerrungen in Form von Holz- und Polster führen.
- 3) Diese eingeschränkte Herstellergarantie gilt nicht für Mängel, die auf unsachgemäßen Gebrauch, Verschleiß, Eingriff durch Dritte oder höhere Gewalt zurückzuführen sind. Sonstige falsche Handhabung, wie z. B. das Ablegen ungeeigneter Objekte, das Hinaufsteigen, das Knien oder die Produkte ins Freie stellen, können sowohl zu Schäden an den Möbelstücken als auch zu Verletzungen des Benutzers führen.
- 4) Bitte geben Sie den Beizton nach Farbton an, wie in unserem Musterkatalog und Website angegeben. Dennoch erwarten Sie keine Nachbildung. Verschiedene Holz- und Furniere nehmen den Beizton anders auf und damit kann es zu Veränderungen von Farbtönen und Texturen kommen. Bezüglich des natürlichen Farbtones, dienen die Farbmuster nur zur Orientierung. Die Oberfläche des Furniers ist leicht unterschiedlich als Massivholz, da es sich um anderes Material handelt.
- 5) Veränderungen in Textur, Farbe und kleinere Abweichungen und natürliche Wachstumsdefekte werden nicht als Fehler betrachtet; im Gegenteil, diese beweisen die Echtheit und Natürlichkeit des Holzes. Als natürliches Element reagiert das Holz immer auf seine Umgebung. Während der Lebensdauer des Produkts kann dieses zu kleinen Rissen in der Farbe oder zu einem leichten Eindringen auf der Oberfläche der Holzstruktur führen. Dieses sollte nicht als Fehler, sondern Naturmaterial angesehen werden.
- 6) Die Garantie umfasst keine Qualitätsmängel, die Stoffe, Echtleder oder Kunstleder betreffen, die für die Polsterung benutzt worden sind, weder noch die nicht-Benutzung der Metallstege für Barstühle. In Bezug auf das Polstern mit Kundenstoff, behalten wir uns das Recht vor, Material, das wir für zum Polstern von unseren Produkten unangemessen sehen, nicht zu akzeptieren. Beim Versenden des Stoffes, achten Sie bitte darauf, dass die Seite, die beim Polstern benutzt werden soll, dementsprechend gekennzeichnet ist. Daher behalten wir uns das Recht vor, die Seite auszuwählen, falls diese nicht gekennzeichnet ist. Insbesondere im Fall von Barhockern, empfehlen wir ein sehr widerstandsfähiges Material.
- 7) Helle Stoffe, Echtleder und /oder Kunstleder können durch den Kontakt mit anderen, dunkleren Materialien wie: gefärbte Stoffe, Jeans, Zeitungen oder Zeitschriften, abfärben. Diese chemische Reaktion von Farbpigmentierung, ist nicht ein Zeichen von schlechter Qualität und ist daher nicht durch die Garantie abgedeckt.
- 8) Die Eigenschaften einiger Polsterstoffe oder in der Polsterung verwendete Technologie, kann einige Schäden an den gepolsterten Produkten verursachen: Leichte Wellen und Falten können auf den gepolsterten Produkten auftreten während des Polsterungsprozesses so wie auch während der Verwendung des Produkts.  
Beim Polstern runder Formen, ist die Faltenbildung des Stoffes technisch gesehen unvermeidbar.
- 9) Für Polsterung der Modelle mit echtem Leder, und Samtstoffen, die vom Kunden geliefert wird, sollte das Material in Rollen kommen. Das Falten des Leders und Samtstoffes sollte vermieden werden, da es zu Verformungen führen kann. In einem solchen Fall, behalten wir uns das Recht vor, das Material zurück zu weisen.  
Leder ist ein Naturprodukt. Aus diesem Grund sollte es einen gewissen Grad an Annahme geben, hinsichtlich der Ungleichheiten auf der Oberfläche und Struktur sowie kleine Defekte, wie Narben, Kratzer, etc., die vom natürlichen Lebensraum des Tieres folgen. Diese Mängel zeigen und beweisen die „Echtheit des Leders“.
- 10) Immer wenn die Polsterung aus echtem Leder oder Kunstleder ist, sollte ein Doppelkeder verwendet werden.
- 11) Die Möbel nicht dem Wasser, übermäßige Erwärmung und direkter Sonneneinstrahlung aussetzen. Als Folge der direkten Sonneneinstrahlung, kann sich der Holzfarbton, Stoff oder Kunststoff ändern.
- 12) Es ist nicht empfehlenswert, die Möbel auf unebenen Bodenbeläge zu stellen, da es zu Schäden an diesen führen kann.
- 13) Die Verwendung von Plastik, Nylon oder Nylon / Metall Gleitern, können Böden aus Holz oder Parkett beschädigen.
- 14) Wir empfehlen in regelmäßigen Abständen den Zustand der Gleiter zu überprüfen, um Schäden an Böden oder Produkten zu vermeiden.
- 15) Scharfe Gegenstände, Schlüssel, Besteck, Handtaschen, härtere Nähte, Reißverschlüsse von Hosen, Krallen von Tieren, etc.. können Schäden am Holz, Furnier und Stoffen verursachen.
- 16) Alle Schrauben sollten regelmäßig angezogen werden. Dadurch wird die Festigkeit und Strapazierfähigkeit des Produkts erhöht. Die Lösung der Verschraubungen kann zu einer übermäßigen Belastung der Bauteile verursachen und zu Schäden an dem Produkt führen.
- 17) Die Sitzhöhe oder die Gesamthöhe des Produktes können der Standard-Abmessungen, je nach Auswahl der Polsterung, variieren.
- 18) Die Ausführung in Stapelbar kann von der Ausführung in nicht Stapelbar Bezug auf Stege, Sitzmöglichkeiten, Form der Füße und Armlehnen abweichen.

**Die Garantie von Fenabel - The Heart of seating, deckt nicht die Nichtbeachtung dieser Empfehlungen.**

**ES**

- 1) Teniendo en cuenta nuestra política de mejora continua, nos reservamos el derecho a modificar el producto en relación a su diseño, materiales, construcción y tecnología de producción. Nos esforzamos en mejorar el valor y el diseño del producto. Las dimensiones que se muestran en el catálogo son de carácter orientativo y pueden diferir en casos particulares.
- 2) Los muebles están diseñados para una utilización en interiores en condiciones estándar, con una humedad relativa entre 25 y 60% y una temperatura de entre 18 y 24 ° C. Si no, tendrá efectos negativos sobre los muebles y puede dar lugar a distorsiones en la forma de la madera y de la tapicería.
- 3) La garantía no cubre los defectos o desgaste causados por el uso normal del producto o daños causados por accidentes o mal manejo durante la instalación. Otros usos, como usar nuestros productos para apoyar objetos inapropiados, subirse a los mismos, arrodillarse, saltar, dejarlos caer, golpearlos o colocarlos en el exterior, pueden provocar daños en el mobiliario, con el daño potencial para el usuario.
- 4) Por favor, especifique el acabado según las muestras de color que aparecen en nuestro catálogo y sitio web. Sin embargo, éstos deben considerarse como una guía general y orientativa, por lo que no se debe esperar que sean una réplica exacta sobre el resultado final. Diferentes maderas y chapas pueden absorber acabados de manera diferente, y por lo tanto, pueden causar variaciones de tonos y texturas. Con respecto al color natural, las muestras de color son sólo a modo orientativo. El acabado de la chapa es ligeramente diferente al de la madera dura, ya que éste no es el mismo material.
- 5) Los cambios en la textura, pequeñas variaciones de color y defectos de crecimiento naturales no se consideran defectos; por el contrario, confirman la naturaleza genuina de la madera. Al ser un material natural, la madera reacciona de forma permanente con el medio ambiente. Esta reacción puede consistir en pequeñas grietas en la pintura o una ligera penetración de la misma en la estructura de la madera durante el ciclo de vida del producto. Esto no debe considerarse como un defecto de fabricación, sino una consecuencia directa de la condición "natural" de la madera.
- 6) La garantía no cubre la calidad de la tela, el cuero natural o las poli pieles usadas en productos tapizados, ni la omisión de una protección de metal apropiada para los taburetes. Con respecto a los tejidos proporcionados por el propio cliente, nos reservamos el derecho a no aceptar ningún material que consideremos inapropiado para tapizar nuestros productos. Al enviar la tela, no olvide en señalar el lado que desea utilizar para el tapizado. Nos reservamos el derecho a elegir el lado cuando éste no haya sido indicado por el cliente. En el caso de los taburetes, en particular, se recomienda el uso de materiales con una mayor resistencia a la abrasión.
- 7) Telas, cuero natural y / o poli pieles más ligeras se pueden teñir al entrar en contacto con otros materiales más oscuros, como tejidos teñidos, pantalones de mezclilla, periódicos, revistas, etc. Esta reacción química del color de pigmentación no es un signo de mala calidad y, por tanto, no está cubierta por la garantía.
- 8) Las características propias de algún tipo de tapizado o la propia tecnología utilizada en el proceso del tapizado, pueden causar algún desperfecto menor en el producto, tales como la aparición de pequeñas arrugas u ondas en el propio tapizado durante su proceso de fabricación o como consecuencia del uso del producto. Por tanto, no están sujetos a ninguna reclamación por parte del cliente. Cuando se tapiza con formas redondas, las arrugas y el arrugamiento del material de la tapicería es técnicamente inevitable.
- 9) Para la tapicería en cuero natural o terciopelo suministrado por el cliente, el material debe ser enviado en rollos. Evitar doblar el cuero o terciopelo ya que puede causar deformaciones. En caso de que esto suceda, nos reservamos el derecho de rechazar el material. El cuero natural es un producto natural y es por esta razón que debe haber un grado de tolerancia en relación a las desigualdades en la superficie y la estructura, así como pequeños defectos tales como pequeñas grietas, abrasiones, etc. siendo esto el resultado de la propia vida del animal. Estos defectos sólo certifican la "autenticidad" del cuero natural.
- 10) Cuando el tapizado es en cuero natural o poli piel se debe aplicar vivo doble.
- 11) No exponga los muebles al agua, al calor excesivo o a la luz solar directa. Como resultado de la exposición directa a la luz solar, el color de la madera, tela o plástico puede cambiar.
- 12) No se recomienda el uso de los muebles en el pavimento desigual, ya que puede dañar el mobiliario.
- 13) El uso de tacos de plástico, nylon o combinaciones de nylon / metal puede dañar el suelo de madera o parquet.
- 14) Se recomienda comprobar el estado de los tacos periódicamente para evitar daños en el suelo o en el producto.
- 15) Los objetos afilados, llaves, cubiertos, bolsos de mano, costuras duras, las cremalleras de los pantalones, las garras de los animales domésticos, etc., pueden dañar la madera, chapa de madera y tela.
- 16) Todos los tornillos y clavos deben ajustarse periódicamente para garantizar la durabilidad y resistencia del producto. El juego en las uniones puede causar tensión en los componentes y provocar daños en el producto.
- 17) La altura del asiento y la altura global del producto pueden variar de las dimensiones estándar dependiendo de la opción del tapizado.
- 18) La versión apilable puede diferir de la versión no apilable relativamente a la forma de la travessa del asiento, forma de las piernas y los brazos.

**La garantía de Fenabel - The heart of seating, NO CUBRE el incumplimiento de estas recomendaciones**

- 1) 考虑到我们公司的长期持续发展，公司保留改变产品的设计，材料，构造，和产品技术的权利。我们致力于提高产品价值和设计。目录册的尺寸均为设计尺寸，具体尺寸可根据实际情况改变。
- 2) 家具设计使用于室内25%到65%空气相对湿度，18到24摄氏度的环境内。在这个环境之外可能对木材或者软包有负面影响。
- 3) 质保范围不包括错误安装所导致的产品瑕疵。也不包括户外的适用或者在产品上攀爬、跪、跳，产品的跌落、用产品敲打等不当适用。
- 4) 请根据木样确定便面处理。我们的目录册和网站的木样仅供参考。因此，真实产品可能与目录册或网站上图片有合理出入。不同种类的木材或木皮具有吸附颜色的能力，这可能影响最终家具成品的颜色。
- 5) 木材的纹路的改变、细微色差和天然生长瑕疵不作为不良品。他们是木材天然成长的证明。作为天然原材料，木材对环境的变化会有所反映。可能导致轻微的开裂或者表面的渗透。这个不在质保范围内。
- 6) 质保范围不包括面料、真皮、人造皮等所有软包材料的瑕疵以及吧椅脚踏的瑕疵。关于客供软包材料，我们有权不接受我们认为不适合做软包产品的材料。在寄出材料之前，请在材料上标记好“表面”“反面”，如果无标记，我们有权选择材料的表面。关于吧椅的脚踏，我们建议使用耐磨的材料。
- 7) 和染色面料、斜纹布、报纸、杂志等深色材料接触后，面料、真皮或者人造皮可能会染色。这个是颜色的化学染色，不属于质量瑕疵，因此不在质保范围内。
- 8) 部分软包材料的特性或者技术可能对产品导致软包产品的破损，比如在软包过程或使用过程上出现的表面的轻微破裂或者皱纹。这些不在质保范围内。户型软包会出现皱纹，这个是无可避免的。
- 9) 关于客供的真皮材料或者丝绒面料，需要卷筒包装。避免真皮和丝绒的折叠，因为这样会导致材料变形。万一这种情况发生，我们有权拒收材料。真皮是天然材料，因此某种程度上的表面或者结构的不对称是可接受的，同样，如天然动物皮毛的疤痕、抓痕等不视作质量缺陷。
- 10) 请不要把家具直接接触水，极度高温和直接阳光的环境里。在阳光中直接暴晒可能造成木质产品颜色和面料颜色的掉落，胶质产品的改变。
- 11) 我们不建议在不平的地面使用家具，因为这会导致家具的破损。
- 12) 塑料、尼龙或者金属的脚套可能会损坏木地板或者拼花地板。
- 13) 双装饰封边适用于真皮或人造皮的产品软包上。
- 14) 我们建议定期检查脚套的状况以避免对地面或者产品的损坏。
- 15) 尖利的物品，如：钥匙、刀具、女士包、拉链、宠物链等等可能会对木、木饰面和面料造成伤害。
- 16) 所有螺丝应该定期上紧，这样可以保证产品的耐用性和牢固性。连接处的松懈可导致部件的受力过度而损坏产品。
- 17) 根据所选的软包方式不一样，坐垫的高度和产品的整体高度可能和标准尺寸不同。
- 18) 可叠加椅子与不可叠加椅子的尺寸会不一样，因为他们使用不同的连接方式、坐垫、脚和扶手。

Fenabel 的质保范围不包括上诉的情况导致的产品损坏。

# MAINTENANCE AND CLEANING ADVICE

Conselhos de Manutenção e Limpeza | Conseil d'Entretien de Néttoyage | Produkt- und Pflegehinweise | Consejos de Mantenimiento y Limpeza

家家具清洁和维护建议 具清洁和维护建议

## **i** WOOD AND VENEER

Madeira e Folheado | Bois et Placage | Holz und Furnier | Madera y Chapeado de Madera

- EN**
- Wood and veneer are affected by light and sources of heat. For the first 6–8 weeks, when the item is absorbing the surrounding light, keep the surfaces clear of any objects to avoid permanent marks and circles.
  - Protect wood and veneer from direct sunlight to prevent colour fading
  - Water must be used in small quantities and only in the form of a damp cloth. After wiping, always use a dry cloth
  - Wood and veneer are very sensitive to liquids. Wipe up spilled liquids immediately
  - Always try to remove stains with the mildest cleaning materials. A suitable soap solution is made from ¼ dl soap powder to 1 litre of warm water
  - Never use the agents containing benzene and other solvents.
- PT**
- A madeira e o folheado são afectados pela luz e pelo calor. Durante as primeiras 6 a 8 semanas, quando o produto estiver a absorver inicialmente a luz circundante, mantenha as superfícies livres de quaisquer objectos para evitar marcas e círculos permanentes.
  - Proteja a madeira e o folheado da luz solar directa para prevenir o esbatimento das cores.
  - Só deve usar-se água em pequenas doses e apenas num pano húmido. Depois de limpar, use sempre um pano seco.
  - A madeira e o folheado são sensíveis aos líquidos. Limpe imediatamente líquidos derramados.
  - Tente sempre remover manchas usando o material de limpeza mais suave. Uma solução de sabão adequada é constituída por ¼dl de sabão em pó por 1 litro água quente.
  - Nunca utilizar produtos que contenham benzeno ou outros solventes.
- FR**
- Les bois et placages peuvent être altérés par la lumière et par les sources de chaleur. Il est conseillé de ne pas poser d'objet sur votre nouveau meuble les 6 à 8 premières semaines pendant lesquelles il est exposé à la lumière du soleil, afin d'éviter les marques.
  - Protégez le bois et le placage de la lumière directe solaire afin d'éviter la décoloration.
  - L'eau doit être utilisée avec parcimonie et seulement avec un chiffon. Après l'essuyage, utilisez toujours un chiffon sec.
  - Les bois et placages sont très sensibles aux liquides. Essayez immédiatement les éclaboussures.
  - Essayez toujours d'éliminer les tâches avec les produits les plus doux. Une solution savonneuse correcte contient 25 dl de lessive par litre d'eau chaude.
  - Ne jamais utiliser des agents contenant du benzène et autres solvants.
- DE**
- Holz und Furnierholz werden durch Licht und Wärme beeinflusst. Während der ersten 6 bis 8 Wochen nimmt das Produkt die ersten Lichtstrahlen an, deshalb empfehlen wir die Oberflächen von Gegenständen freizuhalten um Abdrücke zu vermeiden.
  - Bitte das Holz und Furnier nicht der direkten Sonneneinstrahlung aussetzen. Farbveränderungen möglich.
  - Bei der Pflege aller Holz Möbel ist besonders darauf zu achten, dass diese niemals nass, sondern nur mit einem feuchten Tuch ohne Zusatz von Pflegemitteln gereinigt werden dürfen.
  - Die Fläche muss sofort getrocknet werden, da es sonst zu Lackschäden kommen kann.
  - Versuchen Sie immer, zum Entfernen der Flecken, sanfte Reinigungsmittel zu benutzen. Geeignete Seifenlösung besteht aus 1/4 dl Seife pro 1 L warmes Wasser.
  - Niemals Produkte mit Benzol oder andere enthaltenden Lösungsmittel benutzen.
- ES**
- La luz y las fuentes de calor afectan a la madera y a la chapa de madera. Durante las primeras seis a ocho semanas, cuando el mueble está absorbiendo por primera vez la luz que lo rodea, no colocar objetos ni ningún tipo de decoración sobre las superficies. La absorción irregular de luz puede producir marcas y círculos permanentes.
  - Proteger la madera y el chapeado de la luz directa solar para prevenir el desvanecimiento de los colores.
  - Sólo se ha de utilizar agua en pequeñas cantidades y únicamente aplicándola con un paño húmedo. Después del paño húmedo, pasar siempre un paño seco.
  - La madera y la chapa de madera son muy sensibles a los líquidos. Por lo tanto, hay que limpiar inmediatamente el líquido que se derrame sobre ellas.
  - Intentar siempre a eliminar las manchas con los productos de limpieza más suaves. Una solución jabonosa adecuada está formada por ¼ dl de jabón en polvo por 1 litro de agua tibia.
  - Nunca usar los agentes que contengan benceno y otros solventes.
- CN**
- 实木和木皮可因光线和热源而改变。在开始的6-8当产品吸收周围的光时，请保持表面不要放置任何物品以避免永久的标记和痕迹。
  - 防止实木和木皮直接暴露于太阳底下，以免掉色。
  - 不可用大量水来擦拭，仅用潮湿毛巾擦拭。用完湿布后，请用干毛巾抹干。
  - 实木与贴皮表面对液体十分敏感，若溢出液体，请马上擦拭。
  - 对于很难移除的污点要用温和的清洁液擦拭，最合适的方法是用1/4的肥皂融合在1公斤的温水中，然后再擦拭
  - 请不要使用苯溶剂和带有此成分的产品擦拭家具。

## IRON STAINLESS STEEL

Ferro/ Aço Inox | Fer/Acier Inoxydable | Eisen / Edelstahl | Hierro/Acero Inoxidable | 钢铁质产品

- EN**
- Wipe the whole surface with a clean, soft cloth wrung in soapy water;
  - Wipe dry with a clean cloth.
- FR**
- Essuyez légèrement toute la surface avec un chiffon doux et propre, imbibé d'eau savonneuse;
  - Utilisez un chiffon doux et sec.
- ES**
- Limpiar suavemente toda la superficie con un trapo suave y limpio mojado en agua jabonosa suave y bien escurrido;
  - Secar con un paño limpio.
- PT**
- Limpe suavemente toda a superfície com um pano limpo, macio e humedecido com água com sabão neutro;
  - Limpe, de seguida, com um pano seco.
- DE**
- Reinigen Sie die gesamte Oberfläche mit einem sauberen, weichen Tuch, das mit Wasser und einer milden Seife befeuchtet ist,
  - Danach mit einem fusselfreien Tuch trocken nachwischen.
- CN**
- 拧干沾有肥皂水的布来擦拭表面
  - 用干净的干布来擦拭

# FABRICS

Ferro/ Aço Inox | Fer/Acier Inoxydable | Eisen / Edelstahl | Hierro/Acero Inoxidable | 钢铁质产品

- EN**
- Protect the fabric from direct sunlight to prevent colour fading
  - Never rub the stains and clean immediately;
  - Ordinary cleaning: Vacuum frequently and use a damp cloth;
  - Never use the agents containing benzene and other solvents;
  - Removable covers should be dry-cleaned.
- FR**
- Protégez vos tissus de la lumière du soleil pour empêcher que les couleurs ne perdent leur éclat;
  - Ne jamais frotter les taches et les nettoyer avant qu'elles ne sèchent;
  - Entretien courant. Passez souvent l'aspirateur et utilisez un chiffon;
  - Ne jamais utiliser des agents contenant du benzène et autres solvants;
  - Les housses amovibles doivent être nettoyées à sec.
- ES**
- Proteger la tela de la luz solar directa para prevenir el desvanecimiento de los colores;
  - Nunca frotar las manchas;
  - Limpieza normal: limpiar con aspirador y con un paño húmedo;
  - Nunca usar los agentes que contengan benceno y otros solventes;
  - Las fundas extraíbles deben limpiarse en seco.

- PT**
- Proteja o tecido da luz solar directa para prevenir o esbatimento das cores;
  - Nunca esfregue as manchas e limpe antes de secar;
  - Aspire com frequência e use apenas um pano húmido;
  - Nunca utilizar produtos que contenham benzeno ou outros solventes;
  - As capas removíveis devem ser limpas a seco.
- DE**
- Bitte die Stoffe nicht der direkten Sonneneinstrahlung aussetzen. Farbveränderungen möglich;
  - Reiben Sie niemals die Flecken; sofort säubern;
  - Gewöhnliche Reinigung: regelmäßig saugen und benutzen Sie nur ein feuchtes Tuch;
  - Niemals Produkte mit Benzol oder andere enthaltenden Lösungsmittel benutzen;
  - Abnehmbare Bezüge müssen trocken gereinigt werden.
- CN**
- 保护家具免受太阳直接照射, 以免褪色
  - 千万不要擦污渍和清洁紧接
  - 正常清洗: 经常吸尘和用略带潮湿的布擦
  - 不要使用苯溶剂和带有此成分的产品擦拭家具
  - 椅套可干洗

# FAUX LEATHER

Semi Peles | Simili Cuir | Kunstleder | Polipielles | 半皮革面料

- EN**
- Protect the faux leather from direct sunlight and sources of heat to prevent colour fading;
  - For general cleaning only use a dry soft cloth;
  - Never rub the stains;
  - Never use the agents containing benzene and other solvents;
  - If necessary, wipe the whole surface with a clean, soft cloth wrung in soapy water;
  - If vacuum cleaning, use a soft brush nozzle to avoid scratching the surface;
  - Pay attention to the migration of dyes.
- FR**
- Tenez le simili cuir à l'écart de la lumière du soleil ou des sources de chaleur, pour empêcher que les couleurs ne perdent de leur éclat;
  - Utilisez un chiffon doux et sec pour le nettoyage courant;
  - Ne jamais frotter les taches;
  - Ne jamais utiliser des agents contenant du benzène et autres solvants;
  - Si nécessaire, essuyez légèrement toute la surface avec un chiffon doux et propre, imbibé d'eau savonneuse;
  - Passez l'aspirateur avec un embout brosse douce pour éviter d'érafler la surface;
  - Faire attention au transfert des teintures.
- ES**
- Proteger la polipiel de la luz solar directa y de las fuentes de calor;
  - Para la limpieza general, utilizar únicamente un paño suave seco;
  - Nunca frotar las manchas;
  - Nunca usar los agentes que contengan benceno y otros solventes;
  - Si es necesario, limpiar suavemente toda la superficie con un trapo suave y limpio mojado en agua jabonosa y bien escurrido;
  - Si limpiar con el aspirador, utilizar una boquilla de cepillo suave para no rayar la superficie;
  - Prestar atención a la migración de los colorantes.

- PT**
- Proteja as semi peles de fontes de calor e da luz solar directa;
  - Para a limpeza geral use apenas um pano macio e seco;
  - Nunca esfregue as manchas e limpe antes de secar;
  - Nunca utilizar produtos que contenham benzeno ou outros solventes;
  - Se for necessário, limpe suavemente toda a superfície com um pano limpo, macio e humedecido com água com sabão;
  - Se aspirar, use um bocal com escova macia para evitar riscar a superfície;
  - Ter atenção à migração das tinturas.
- DE**
- Bitte schützen Sie Kunstleder vor der direkten Sonneneinstrahlung und von anderen Wärmequellen;
  - Für die allgemeine Reinigung nur ein trockenes, weiches Tuch benutzen;
  - Die Flecken niemals reiben;
  - Niemals Produkte mit Benzol oder andere enthaltenden Lösungsmittel benutzen;
  - Falls notwendig, wischen Sie die gesamte Oberfläche mit einem sauberen, weichen Tuch, das mit Seifenwasser angefeuchtet ist;
  - Falls Sie saugen, benutzen Sie eine feine Staubsaugerbürste um Kratzer auf der Oberfläche zu vermeiden. Sanfte Reinigungsmittel benutzen, wie z. B. Wasser und Seife;
  - Achten Sie auf die Migration von Farbstoffen.
- CN**
- 防止半皮革制品受到太阳直射和其他热源, 以免颜色掉落
  - 用干软布来进行正常擦拭。
  - 不要用力擦拭污垢
  - 不要使用苯溶剂和带有此成分的产品擦拭家具。
  - 如果用吸尘器清洁, 用软扫来吸尘, 防止刮花表面
  - 如有需要, 请用软的沾有肥皂水的干净布来擦拭。



- We waive all responsibility for problems that arise out of ignoring the cleaning instructions.
- Estamos isentos de qualquer responsabilidade por problemas originados pelo incumprimento das instruções de lavagem, utilização e manutenção.
- Nous dégageons toute responsabilité quant aux problèmes encourus liés au non respect des consignes d'entretien.
- Wir übernehmen keine Verantwortung oder Haftung für Probleme oder Schäden in jeglicher Form die durch die Nichtbeachtung der Reinigungshinweise entstehen.
- Renunciaremos a toda responsabilidad por los problemas que surgen de ignorar las instrucciones de limpieza.
- 不当清洁引起的问题不在我们质保范围内。

# Many Thanks to

Agradecimentos | Remerciements | Danksagung | Agradecimientos | 鸣谢

Fenabel Lda, would like to thank all those who assisted and were involved in the creation of this catalogue. It is an achievement that would not have been possible without the help of a considerable number of people.

Thanks to all.

A Fenabel Lda, gostaria de prestar um profundo agradecimento a todos quanto, de alguma forma, se empenharam para que este catálogo se tornasse uma realidade. É igualmente o culminar de um objectivo que não seria possível sem a ajuda de um número considerável de pessoas.

Muito obrigado a todos.

Fenabel Lda, aimerait remercier tous ceux, qui de quelconque façon, se sont efforcés pour que ce catalogue soit une réalité. Cela est également l'aboutissement d'un objectif, qui ne serait possible sans l'aide de nombreuses personnes.

Merci à tous.

Fenabel Lda. bedankt sich herzlich bei allen, die sich für die hervorragende Ausarbeitung dieses Katalogs eingesetzt haben. Dies ist ebenfalls der Höhepunkt eines Zieles, welches nicht erreichbar gewesen wäre ohne die Hilfe einer beträchtlichen Zahl von Menschen.

Vielen Dank an alle.

Fenabel Lda, quiere expresar su profundo agradecimiento a todos los que, se empeñaron para que este catálogo fuese una realidad. Es la culminación de un objetivo que no habría sido posible sin la colaboración de un número de personas.

Gracias a todos.

Fenabel 非常感谢所有协助和创建这个目录册的人。没有这部分人的帮助这个成就不可能完成。  
谢谢所有的人。

---

**All technical details are for reference only and are based on the example shown in the picture. The company reserves the right to change or amend any product show at any time, even without prior notice.** Toda a informação técnica é só de referência e baseada no modelo da foto. A empresa reserva-se o direito de modificar ou alterar em qualquer momento os produtos sem aviso prévio. Tous les détails techniques sont uniquement pour information et sont basés sur les modèles de la photo. L'entreprise se réserve le droit de modifier ou changer à tous moments les produits sans préavis. Alle technischen Informationen sind nur als Referenz, und basierend auf der Abbildung des Fotos. Wir behalten uns das Recht zur Änderung der Produkte ohne Vorankündigung. Todos los detalles técnicos són para referencia solo y se refieren al modelo en la foto. La empresa se reserva el derecho de modificar o cambiar en cualquier momento los productos sin avisar con antelación. 所有技术细节仅供参考, 是基于在图片显示的示例 在任何时候, 甚至没有在提前告知的情况下, 公司有权修改和改进所有展示的产品。

**Our complete product range is solely meant to be used indoor. Please do not ever put our items outside.**

Toda a nossa gama de produtos foi desenhada para ser utilizada no interior. Por favor nunca os coloque no exterior.

Notre gamme complète de produits est uniquement destinée à être utilisée à l'intérieur. Merci de ne jamais mettre nos articles à l'extérieur. Unsere komplette Produktpalette ist ausschließlich für den Innenbereich gedacht. Unsere Artikel niemals in den Außenbereich stellen. Toda nuestra gama de productos está diseñada para ser utilizada en el interior. Por favor, no los ponga nunca en el exterior. 我们目录册的所有产品仅限于室内使用, 请不要户外使用。

**Copyright.: Any reproduction of text or pictures is strictly forbidden without former written authorization from the company.**

Direitos de Autor.: a reprodução de texto ou imagem é estreitamente proibida sem a autorização escrita da empresa.

Droit d'auteur.: Toute reproduction de texte ou d'images est strictement interdite sans autorisation écrite de l'entreprise.

Urheberrecht: Wiedergabe von Text oder Bild ist ohne schriftliche Genehmigung der Firma verboten.

Derechos de autor.: La reproducción del texto o imágenes está estrictamente prohibida sin autorización escrita de la empresa. 版权:任何复制的文本或是图片在没有授权的情况下是严格禁止的。

**All models are registered and patented**

Todos os produtos estão registados e patenteados

Marque et modèles déposés, tous droits réservés

Alle Marken sind registriert und patentiert

Todos los modelos están registados y patentados.

所有产品都已经注册版权

## Credits

Catalog Design and Art Direction / *Design do Catálogo e Direção Criativa*  
Alexandre Botelho e Nuno Rabbit

Photography & Image Edit / *Fotografia e Edição de Imagem*  
Ultimagem - Manuel Barbosa e Nuno Rabbit

Printing / *Impressão*  
Ultimagem



100% MADE IN PORTUGAL

CERTIFICAÇÃO \_\_\_\_\_



APOIOS \_\_\_\_\_



UNIÃO EUROPEIA  
Fundos Europeus Estruturais  
e de Investimento



